

Adjustable Low Dropout 700mA Linear Regulator

Features

- **Input Voltage Range: 1.42V~3.47V**
- **Low Supply Current: 100mA (Max.)**
- **Low Dropout Voltage: Typically 280mV at 700mA**
- **Adjustable Output Voltage**
- **Output Accuracy: $\pm 1\%$ Over Line, Load, and Temperature Range**
- **Guaranteed 700mA Output Current**
- **Internal Soft start: 0.6ms**
- **Current Limit and Short Current Limit Protections**
- **Over-Temperature Protection**
- **Open Drain VOUT Voltage Indicator (POK)**
- **Shutdown/Enable Control Function**
- **Stable with MLCC**
- **Lead Free and Green Devices Available (RoHS Compliant)**

General Description

The APL5701/2 is a P-channel low dropout linear regulator which needs only one input voltage from 1.42V to 3.47V, and delivers current up to 700mA to set output voltage. It also can work with low ESR ceramic capacitors and is ideal for using in the battery-powered applications such as notebook computers and cellular phones. Typical dropout voltage is only 75mV at 700mA loading. The APL5701/2 integrates many functions. A POK indicates that the output voltage status with a delay time set internally. It can control other converter for power sequence. The APL5701/2 can be enabled by other power systems. Pulling and holding the EN voltage below 0.4V shuts off the output. The functions of thermal shutdown and current-limit protect the device against thermal and current over-loads.

The APL5701/2 is available in a SOT-23-5, SOT-23-6, SOP-8P, TDFN3x3-10 and TDFN2x2-8 packages.

Applications

- Cellular Phones
- Portable and Battery-Powered Equipments
- Notebook and Personal Computers

Simplified Application Circuit

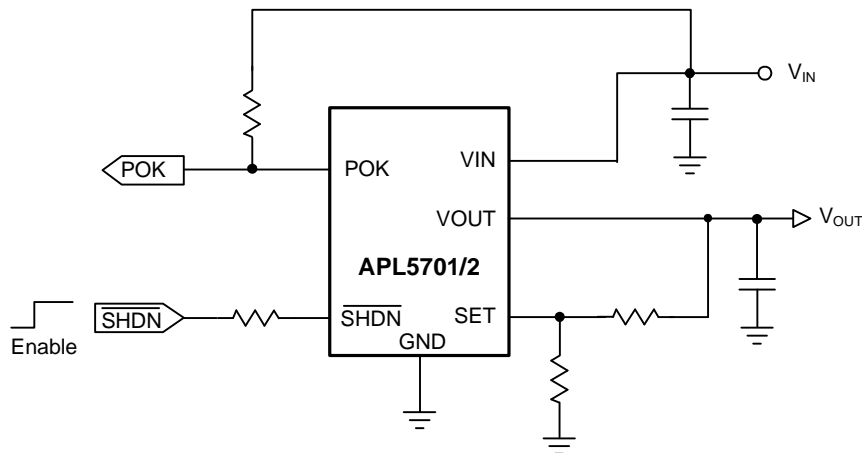

ANPEC reserves the right to make changes to improve reliability or manufacturability without notice, and advise customers to obtain the latest version of relevant information to verify before placing orders.

Pin Configuration

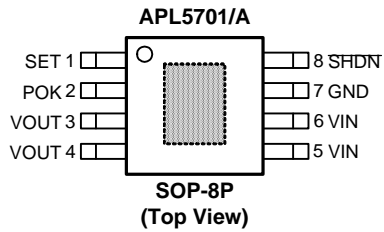
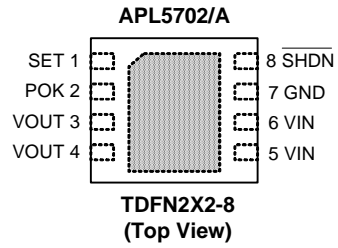
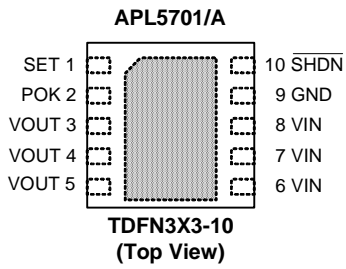
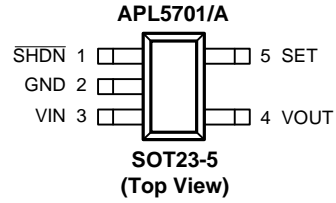
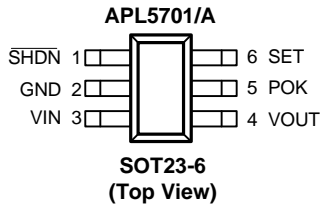

= Exposed Pad (connected to ground plane for better heat dissipation)

Ordering and Marking Information

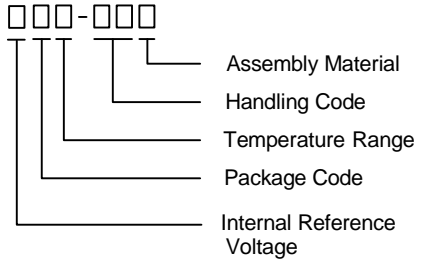
<p>APL5701 APL5702</p>  <p>Assembly Material Handling Code Temperature Range Package Code Internal Reference Voltage</p>	<p>Internal Reference Voltage Blank : 0.8V A : 0.6V Package Code B : SOT-23-5 QB : TDFN 2X2-8 TDFN 3X3-10 C : SOT-23-6 KA : SOP-8P Operating Ambient Temperature Range I : -40 to 85°C Handling Code TR : Tape & Reel Assembly Material L : Lead Free Device G : Halogen and Lead Free Device</p>		
<p>APL5701 QB: <table border="1" data-bbox="406 705 502 795"><tr><td>APL 5701 XXXXX</td></tr></table> XXXXX - Date Code</p>	APL 5701 XXXXX	<p>APL5701A QB: <table border="1" data-bbox="1045 705 1141 795"><tr><td>APL 5701A XXXXX</td></tr></table> XXXXX - Date Code</p>	APL 5701A XXXXX
APL 5701 XXXXX			
APL 5701A XXXXX			
<p>APL5701 B: <table border="1" data-bbox="406 817 502 896"><tr><td>701X</td></tr></table> X- Date Code</p>	701X	<p>APL5701A B: <table border="1" data-bbox="1045 817 1141 896"><tr><td>01AX</td></tr></table> X- Date Code</p>	01AX
701X			
01AX			
<p>APL5701 KA: <table border="1" data-bbox="406 918 502 996"><tr><td>APL5701 XXXXX</td></tr></table> X- Date Code</p>	APL5701 XXXXX	<p>APL5701A KA: <table border="1" data-bbox="1045 918 1141 996"><tr><td>L5701A XXXXX</td></tr></table> X- Date Code</p>	L5701A XXXXX
APL5701 XXXXX			
L5701A XXXXX			
<p>APL5702 QB: <table border="1" data-bbox="406 1019 502 1097"><tr><td>5702 X</td></tr></table> X- Date Code</p>	5702 X	<p>APL5702A QB: <table border="1" data-bbox="1045 1019 1141 1097"><tr><td>702A X</td></tr></table> X- Date Code</p>	702A X
5702 X			
702A X			
<p>APL5701 C: <table border="1" data-bbox="406 1131 502 1209"><tr><td>701X</td></tr></table> X- Date Code</p>	701X	<p>APL5701A C: <table border="1" data-bbox="1045 1131 1141 1209"><tr><td>01AX</td></tr></table> X- Date Code</p>	01AX
701X			
01AX			

Note: ANPEC lead-free products contain molding compounds/die attach materials and 100% matte tin plate termination finish; which are fully compliant with RoHS. ANPEC lead-free products meet or exceed the lead-free requirements of IPC/JEDEC J-STD-020D for MSL classification at lead-free peak reflow temperature. ANPEC defines "Green" to mean lead-free (RoHS compliant) and halogen free (Br or Cl does not exceed 900ppm by weight in homogeneous material and total of Br and Cl does not exceed 1500ppm by weight).

Absolute Maximum Ratings (Note 1)

Symbol	Parameter	Rating	Unit
V_{IN}	VIN Supply Voltage (VIN to GND)	-0.3 to 4	V
V_{OUT}	VOUT to GND Voltage	-0.3 to $V_{IN}+0.3$	V
$V_{/SHDN}, V_{SET}, V_{POK}$	/SHDN, SET, POK to GND Voltage	-0.3 to 4	V
T_J	Maximum Junction Temperature	150	°C
T_{STG}	Storage Temperature	-65 to 150	°C
T_{SDR}	Maximum Lead Soldering Temperature, 10 Seconds	260	°C

Note1: Stresses beyond those listed under "absolute maximum ratings" may cause permanent damage to the device. These are stress ratings only and functional operation of the device at these or any other conditions beyond those indicated under "recommended operating conditions" is not implied. Exposure to absolute maximum rating conditions for extended periods may affect device reliability.

Thermal Characteristics (Note2)

Symbol	Parameter	Typical Value	Unit
θ_{JA}	SOT-23-5 Junction-to-Ambient Resistance in free air	240	°C/W
	SOT-23-6 Junction-to-Ambient Resistance in free air	250	
	SOP-8P Junction-to-Ambient Resistance in free air	55	
	TDFN2x2-8 Junction-to-Ambient Resistance in free air	75	
	TDFN3x3-10 Junction-to-Ambient Resistance in free air	55	

Note 2: θ_{JA} is measured with the component mounted on a high effective thermal conductivity test board in free air.

Recommended Operating Conditions (Note3)

Symbol	Parameter	Range	Unit
V_{IN}	VIN Supply Voltage	1.42 to 3.47	V
V_{OUT}	VOUT Output Voltage	APL5701, APL5702	$0.8 \sim V_{IN} - V_{DROP}$
		APL5701A, APL5702A	$0.6 \sim V_{IN} - V_{DROP}$
$V_{/SHDN}$	/SHDN to GND Voltage	0 to 3.47	V
I_{OUT}	VOUT Output Current	0 to 700	mA
R_2	SET to GND Resistance	1 ~ 100	k Ω
C_{IN}	VIN Input Capacitor	1 ~ 100	μ F
C_{OUT}	VOUT Output Capacitor	6.8 ~ 33	μ F
T_A	Ambient Temperature	-40 to 85	°C
T_J	Junction Temperature	-40 to 125	°C

Note 3: Refer to the typical application circuit.

Electrical Characteristics

Unless otherwise specified, these specifications apply over $V_{IN}=V_{OUT}+0.5V$ or $1.5V$, $V_{/SHDN}=V_{IN}$ and $T_A = -40^{\circ}C$ to $85^{\circ}C$. Typical values are at $T_A=25^{\circ}C$.

Symbol	Parameter	Test Conditions	APL5701/2			Unit
			Min	Typ	Max	
UNDER-VOLTAGE LOCKOUT (UVLO) AND SUPPLY CURRENT						
	VIN UVLO Threshold Voltage	VIN rising	1.1	1.25	1.4	V
	VIN UVLO Hysteresis		-	50	-	mV
I _{VIN}	VIN Supply Current	No load, V _{/SHDN} =3.3V	-	50	100	μA
I _{SD}	VIN Supply Current at Shutdown	No load, V _{/SHDN} =0V, V _{IN} =3.47V	-	-	1	μA
OUTPUT VOLTAGE						
V _{REF}	Reference Voltage	APL5701, APL5702	-	0.8	-	V
		APL5701A, APL5702A	-	0.6	-	V
V _{REF}	Reference Voltage Accuracy	I _{OUT} =10mA, T _J =25°C	-0.5	-	+0.5	%
	Line Regulation	I _{OUT} =10mA, V _{IN} =V _{OUT} +0.5V to 3.3V	-0.15	-	+0.15	%/V
	Load Regulation	I _{OUT} =1mA to 700mA	-0.15	0.06	+0.15	%
	Output Accuracy	Over Line, Load, and Temperature Range	-1	-	+1	%
V _{DROP}	Dropout Voltage	V _{IN} =1.5V, I _{OUT} =700mA, T _J =25°C	-	75	100	mV
		V _{IN} =1.5V, I _{OUT} =700mA, T _J =-40°C to 125°C	-	-	135	mV
PSRR	Power Supply Rejection Ratio	f=10kHz, C _{OUT} =6.8μF, I _{OUT} =700mA,	-	50	-	dB
	V _{OUT} Discharge Resistance	V _{IN} =1.5V, V _{/SHDN} =0V, V _{OUT} =0.5V	-	50	-	Ω
	SET Input Current	V _{SET} =0.8V	-100	-	100	nA
POWER OK AND DELAY						
V _{POK}	Rising POK Threshold Voltage	V _{SET} rising	90	92	94	%V _{REF}
	POK Threshold Hysteresis		-	8	-	%V _{REF}
	POK Pull-Low Voltage	POK sinks 5mA	-	0.25	0.4	V
	POK Debounce Interval	V _{SET} < V _{PNOK}	-	10	-	μs
t _{POK}	POK Delay Time	From V _{SET} =V _{POK} to rising edge of the V _{POK}	0.3	0.6	1	ms
/SHDN AND SOFT-START						
V _{/SHDN}	/SHDN Logic High Threshold Voltage	V _{/SHDN} rising	0.4	-	1.5	V
	/SHDN Hysteresis		-	0.1	-	V
	/SHDN Pull Low Resistance		-	3	-	MΩ
t _{D(ON)}	Turn On Delay Time	From /SHDN high engaged to the beginning of V _{OUT} soft start, T _J =25°C	-	200	300	μs
t _{SS}	Soft-Start Time	V _{OUT} rising 10% to 90%	0.3	0.6	1	ms
PROTECTIONS						
I _{LIMIT}	Current Limit Threshold	T _J =25°C	900	1125	1350	mA
		T _J =-40°C to 125°C	750	-	-	mA
I _{SHORT}	Short-Circuit Output Current	V _{SET} < 50%V _{REF}	-	280	-	mA
t _{B(SC)}	Short Current-Limit Blanking Time	From beginning of soft-start	0.6	1.2	-	ms
	Over-Temperature Threshold		-	150	-	°C
	Over-Temperature Hysteresis		-	50	-	°C

Pin Description

PIN					NAME	FUNCTION
NO.						
SOT-23-6	SOT-23-5	TDFN2x2-8	TDFN3x3-10	SOP-8P		
1	1	10	8	8	$\overline{\text{SHDN}}$	Shut Down Control Pin. pulling V_{SHDN} below 0.3V will disable the output.
2	2	9	7	7	GND	Ground pin of the circuitry. All voltage levels are measured with respect to this pin.
3	3	6, 7, 8	5, 6	5, 6	VIN	Main supply input pin for voltage conversions. A decoupling capacitor (10 μ F recommended) is usually connected near this pin to filter the voltage noise and improve transient response. The voltage on this pin is monitored for Power-On-Reset purpose.
4	4	3, 4, 5	3, 4	3, 4	VOUT	Regulator Output. Sources up to 700mA. Bypass with at least a 6.8 μ F MLCC capacitor to GND.
5	-	2	2	2	POK	Power-OK signal output pin. This pin is an open-drain output used to indicate the status of output voltage by sensing SET voltage. This pin is pulled low when output voltage is not within the Power-OK voltage window.
6	5	1	1	1	SET	Set Output Voltage Pin. Connect this pin to ground for fixed output voltage operation. Connect this pin to an external resistor divider for adjustable output voltage mode operation.
-	-	Exposed Pad	Exposed Pad	Exposed Pad	GND	Ground pin of the circuitry. Connect this pad to system ground plane for good thermal conductivity.

Typical Application Circuit

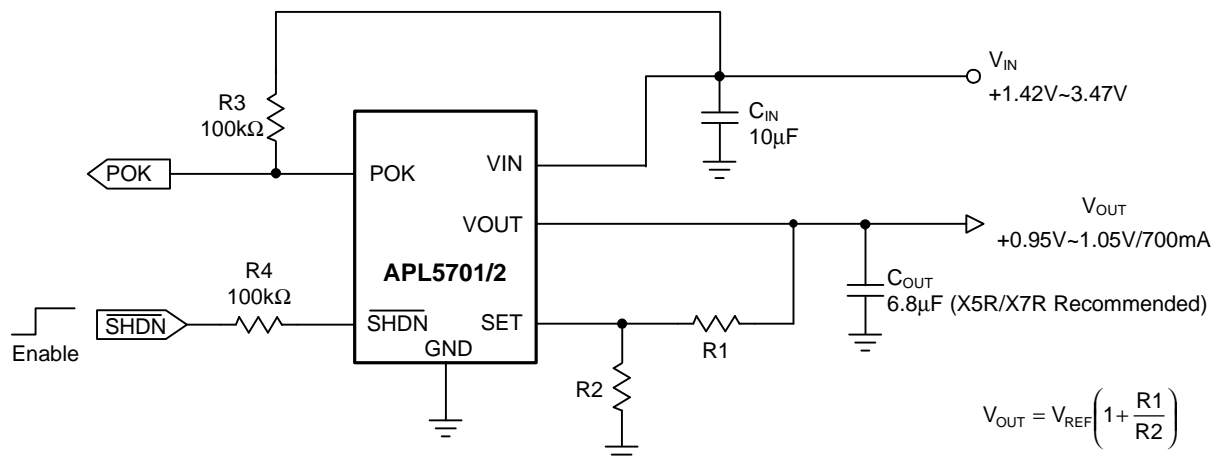

Block Diagram

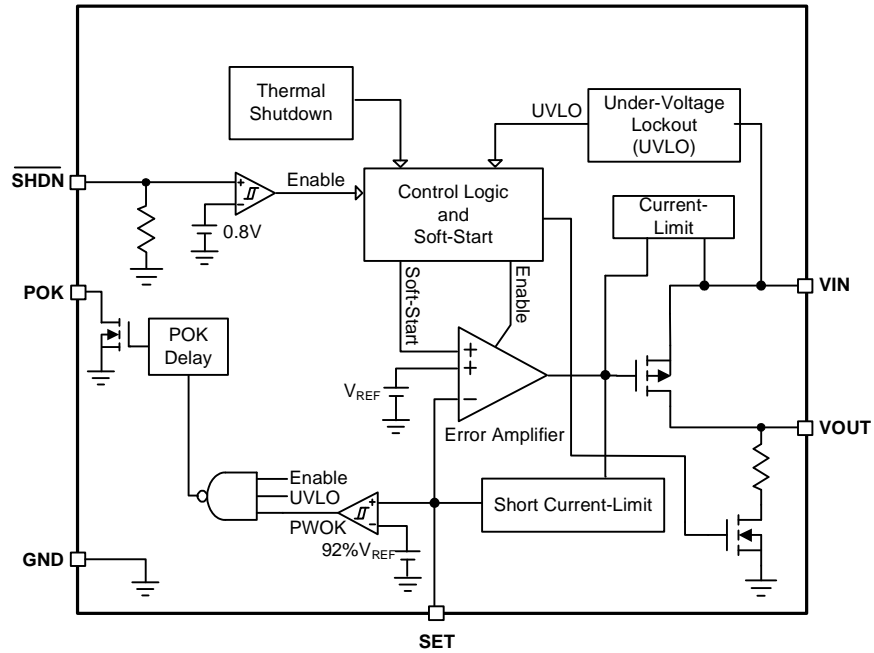

Function Description

VIN Under-Voltage Lockout (UVLO)

The APL5701/2 has a built-in under-voltage lockout circuit to keep the output shut off until internal circuitry is operating properly. The UVLO circuit has a hysteresis and a de-glitch feature so that it will typically ignore undershoot transients on the input.

Soft-Start

The APL5701/2 provides an internal soft-start circuitry to control rise rate of the output voltage and limit the current surge during start-up. Approximate 200 μ s delay time after the V_{IN} is over the UVLO threshold; the output voltage starts the soft-start. The typical soft-start interval is about 600 μ s.

Current Limit Protection

The APL5701/2 provides a current limit protection function. During current limit, the device limits output current at current limit threshold. For reliable operation, the device should not be operated in current limit for extended period time.

Short Circuit Current Limit Protection

When the SET voltage drops below 50% V_{REF} , which is caused by the over load or short circuit, the device limits the output current down to a safe level. The short circuit current limit is used to reduce the power dissipation during short circuit conditions. If the junction temperature is over the over-temperature threshold the device will enter the thermal shutdown. The short current-limit function is disabled for successful start-up during soft-start interval.

Shutdown Control

Pulling the $V_{\overline{SHDN}}$ above 1.5V will enable the LDO output, and pulling $V_{\overline{SHDN}}$ below 0.3V will disable the LDO output. When the LDO output is disabled the supply current is reduced to less than 1 μ A. \overline{SHDN} pin are internally pulled low by a resistor. If shutdown function is not used, connect \overline{SHDN} to VIN for normal operation. The shutdown input is compatible with both TTL and CMOS logic levels.

Over-Temperature Protection

An over-temperature protection circuitry limits the junction temperature of APL5701/2. When the junction temperature exceeds +150 $^{\circ}$ C, the over-temperature protection circuitry disables the LDO outputs, allowing the device to cool down. The LDO outputs are enabled again after the junction temperature cools down by 50 $^{\circ}$ C, resulting in a pulsed output during continuous thermal overload conditions. Over-temperature protection is designed to protect the IC in the event of over temperature conditions. For reliable operation, the junction temperature cannot exceed $T_J=+125^{\circ}$ C.

Power-OK and Delay

The APL5701/2 indicates the status of the output voltage by monitoring the feedback voltage (V_{SET}) on SET pin. As the V_{SET} rises and reaches the rising Power-OK voltage threshold, an internal delay function starts to work. At the end of the delay time, the IC turns on the internal NMOS of the POK to indicate the output is ok. As the V_{SET} falls and reaches the falling Power-OK voltage threshold, the IC turns on the NMOS of the POK.

Application Information

Output Capacitor

The APL5701/2 requires a proper output capacitor to maintain stability and improve transient response. The output capacitor selection is dependent upon ESR (equivalent series resistance) and capacitance of the output capacitor over the operating temperature.

In order to insure the circuit stability, the proper output capacitor value should be larger than 6.8μF. With X5R and X7R ceramic chip capacitors, 6.8μF is sufficient at all operating temperatures.

Input Capacitor

The APL5701/2 requires proper input capacitors to supply current surge during stepping load transients to prevent the input voltage rail from dropping. Because the parasitic inductor from the voltage sources or other bulk capacitors to the VIN pin limit the slew rate of the surge currents, more parasitic inductance needs more input capacitance. Ultra-low-ESR capacitors (such as ceramic chip capacitors) and low-ESR bulk capacitors (such as solid tantalum, POSCap, and Aluminum electrolytic capacitors) can all be used as an input capacitor of VIN. For most applications, the recommended input capacitance of VIN is 10μF.

However, if the drop of the input voltage is not cared, the input capacitance can be less than 10μF. More capacitance reduces the variations of the supply voltage on VIN pin.

Setting Output Voltage

The output voltage is programmed by the resistor divider connected to SET pin. The preset output voltage is calculated by the following equation :

$$V_{OUT} = V_{REF} \cdot \left(1 + \frac{R1}{R2} \right) \dots\dots\dots (V)$$

Where R1 is the resistor connected from VOUT to SET with Kelvin sensing connection and R2 is the resistor connected from SET to GND.

Layout Consideration

1. Please solder the Exposed Pad on the ground pad on the top-layer of PCBs. The ground pad must have wide size to conduct heat into the ambient air through the ground plane and PCB as a heat sink.
2. Please place the input capacitors for VIN pins near the pin as close as possible for decoupling high-frequency ripples.
3. Ceramic decoupling capacitors for load must be placed near the load as close as possible for decoupling high-frequency ripples.
4. To place APL5701/2 and output capacitors near the load reduces parasitic resistance and inductance for excellent load transient response.
5. The negative pins of the input and output capacitors and the GND pin must be connected to the ground plane of the load.
6. Large current paths, shown by bold lines on the figure 1, must have wide tracks.
7. Place the R1 and R2 near the APL5701/2 as close as possible to avoid noise coupling.
8. Connect the ground of the R2 to the GND pin by using a dedicated track.
9. Connect the one pin of the R1 to the load for Kelvin sensing.

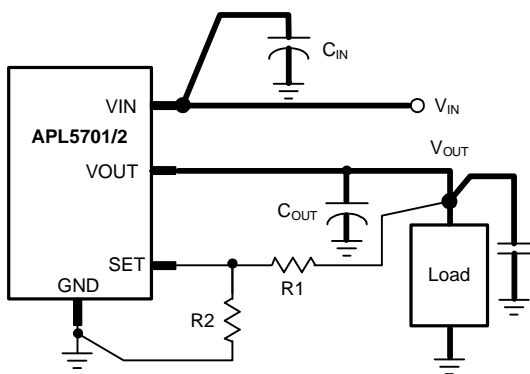
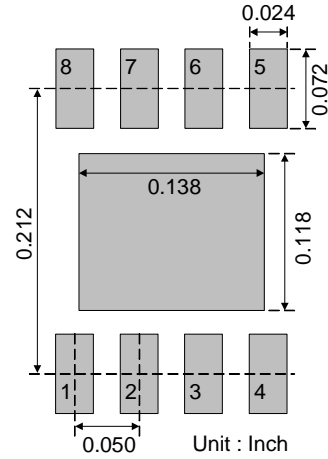
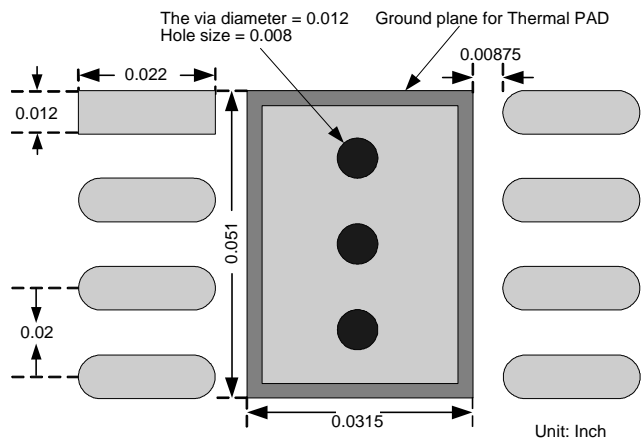

Figure 1

Recommended Minimum Footprint



SOP-8P



TDFN2x2-8

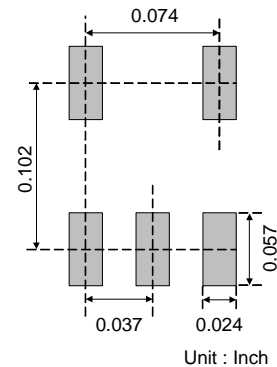

SOT-23-5

Layout Consideration

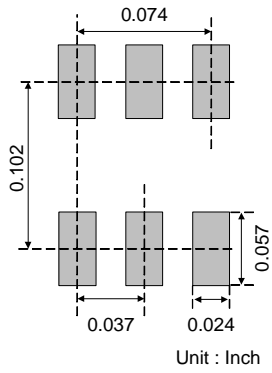

SOT-23-6

Package Information

SOP-8P

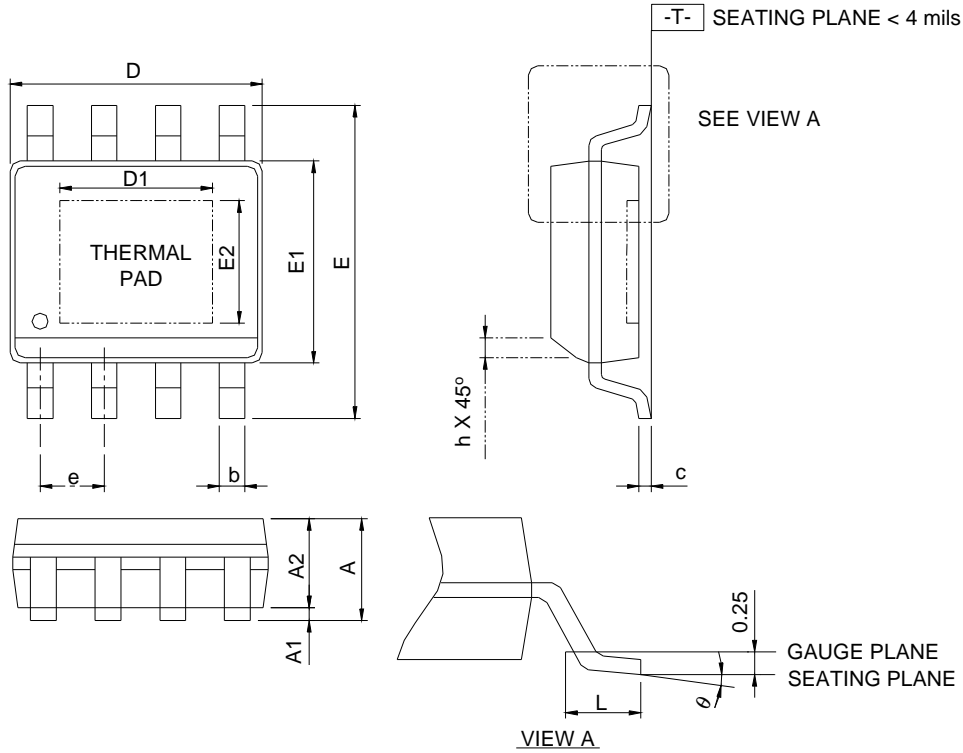

Symbol	SOP-8P			
	MILLIMETERS		INCHES	
	MIN.	MAX.	MIN.	MAX.
A		1.60		0.063
A1	0.00	0.15	0.000	0.006
A2	1.25		0.049	
b	0.31	0.51	0.012	0.020
c	0.17	0.25	0.007	0.010
D	4.80	5.00	0.189	0.197
D1	2.50	3.50	0.098	0.138
E	5.80	6.20	0.228	0.244
E1	3.80	4.00	0.150	0.157
E2	2.00	3.00	0.079	0.118
e	1.27 BSC		0.050 BSC	
h	0.25	0.50	0.010	0.020
L	0.40	1.27	0.016	0.050
theta	0°C	8°C	0°C	8°C

- Note : 1. Followed from JEDEC MS-012 BA.
 2. Dimension "D" does not include mold flash, protrusions or gate burrs. Mold flash, protrusion or gate burrs shall not exceed 6 mil per side .
 3. Dimension "E" does not include inter-lead flash or protrusions. Inter-lead flash and protrusions shall not exceed 10 mil per side.

Package Information

TDFN3x3-10

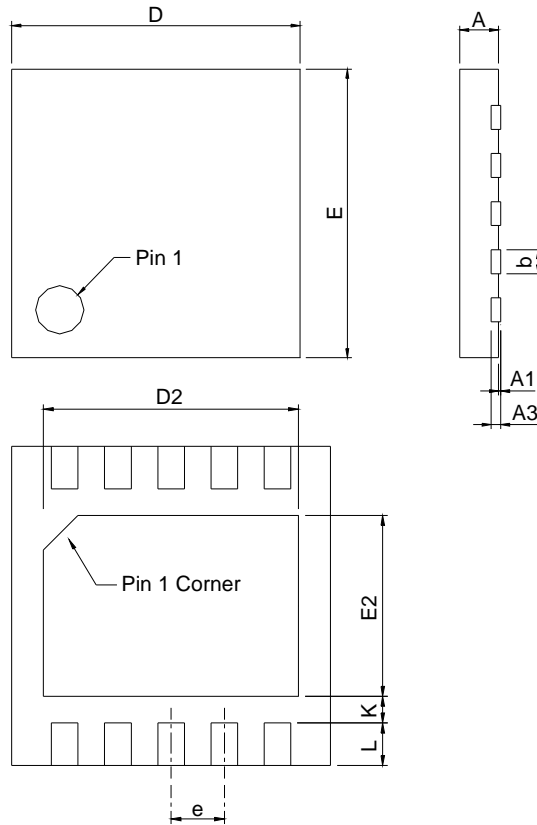

DIMENSIONS	TDFN3x3-10			
	MILLIMETERS		INCHES	
	MIN.	MAX.	MIN.	MAX.
A	0.70	0.80	0.028	0.031
A1	0.00	0.05	0.000	0.002
A3	0.20 REF		0.008 REF	
b	0.18	0.30	0.007	0.012
D	2.90	3.10	0.114	0.122
D2	2.20	2.70	0.087	0.106
E	2.90	3.10	0.114	0.122
E2	1.40	1.75	0.055	0.069
e	0.50 BSC		0.020 BSC	
L	0.30	0.50	0.012	0.020
K	0.20		0.008	

Note : 1. Followed from JEDEC MO-229 VEED-5.

Package Information

SOT-23-6

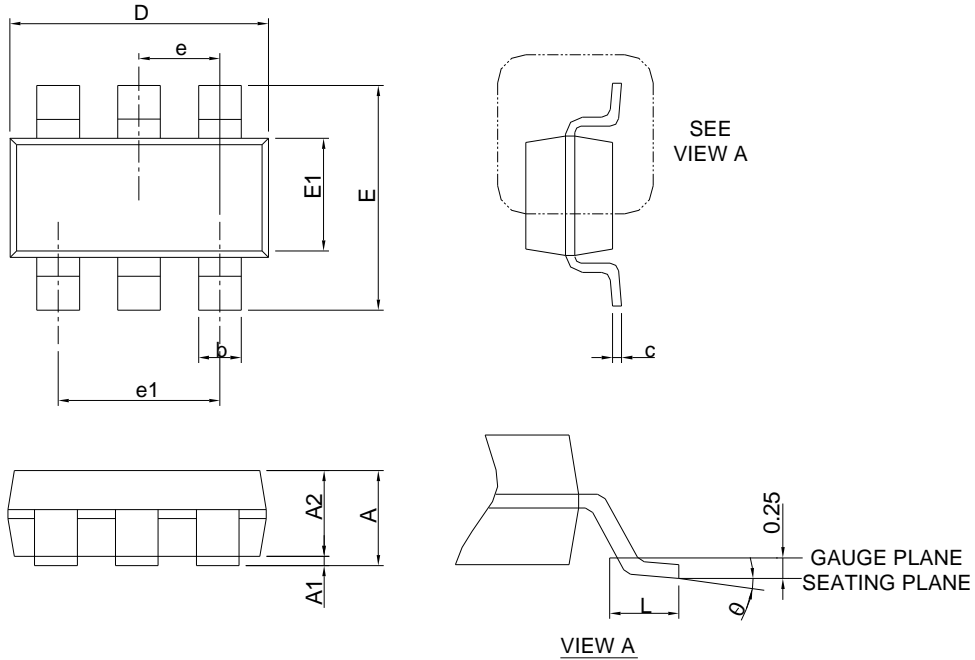

DIMENSIONS	SOT-23-6			
	MILLIMETERS		INCHES	
	MIN.	MAX.	MIN.	MAX.
A		1.45		0.057
A1	0.00	0.15	0.000	0.006
A2	0.90	1.30	0.035	0.051
b	0.30	0.50	0.012	0.020
c	0.08	0.22	0.003	0.009
D	2.70	3.10	0.106	0.122
E	2.60	3.00	0.102	0.118
E1	1.40	1.80	0.055	0.071
e	0.95 BSC		0.037 BSC	
e1	1.90 BSC		0.075 BSC	
L	0.30	0.60	0.012	0.024
θ	0°	8°	0°	8°

Note : 1. Follow JEDEC TO-178 AB.
 2. Dimension D and E1 do not include mold flash, protrusions or gate burrs. Mold flash, protrusion or gate burrs shall not exceed 10 mil per side.

Package Information

SOT-23-5

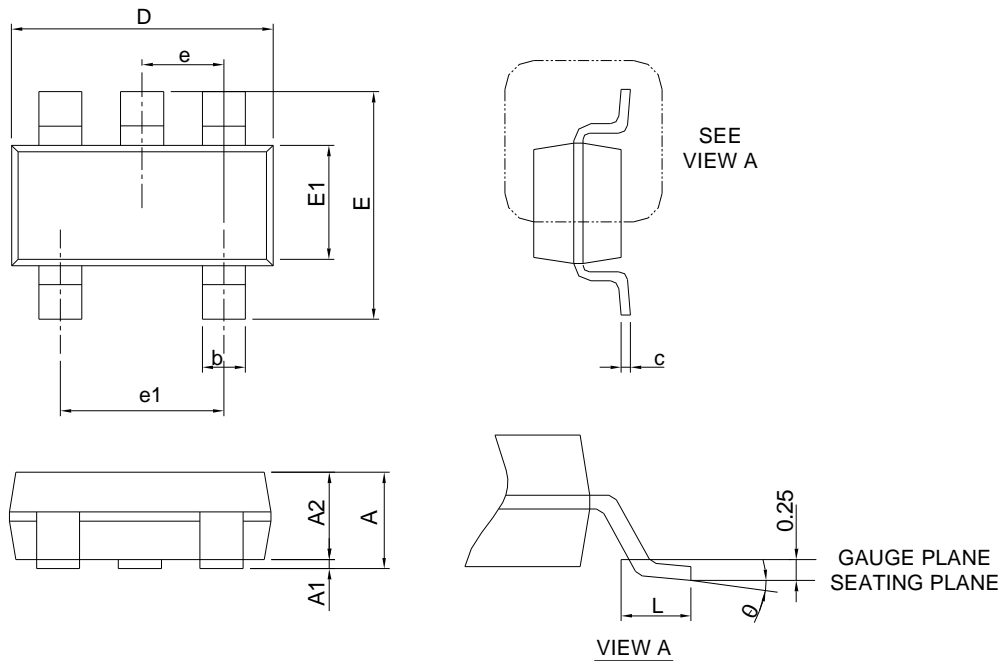

SYMBOL	SOT-23-5			
	MILLIMETERS		INCHES	
	MIN.	MAX.	MIN.	MAX.
A		1.45		0.057
A1	0.00	0.15	0.000	0.006
A2	0.90	1.30	0.035	0.051
b	0.30	0.50	0.012	0.020
c	0.08	0.22	0.003	0.009
D	2.70	3.10	0.106	0.122
E	2.60	3.00	0.102	0.118
E1	1.40	1.80	0.055	0.071
e	0.95 BSC		0.037 BSC	
e1	1.90 BSC		0.075 BSC	
L	0.30	0.60	0.012	0.024
theta	0°	8°	0°	8°

Note : 1. Follow JEDEC TO-178 AA.
 2. Dimension D and E1 do not include mold flash, protrusions or gate burrs. Mold flash, protrusion or gate burrs shall not exceed 10 mil per side.

Package Information

TDFN2x2-8

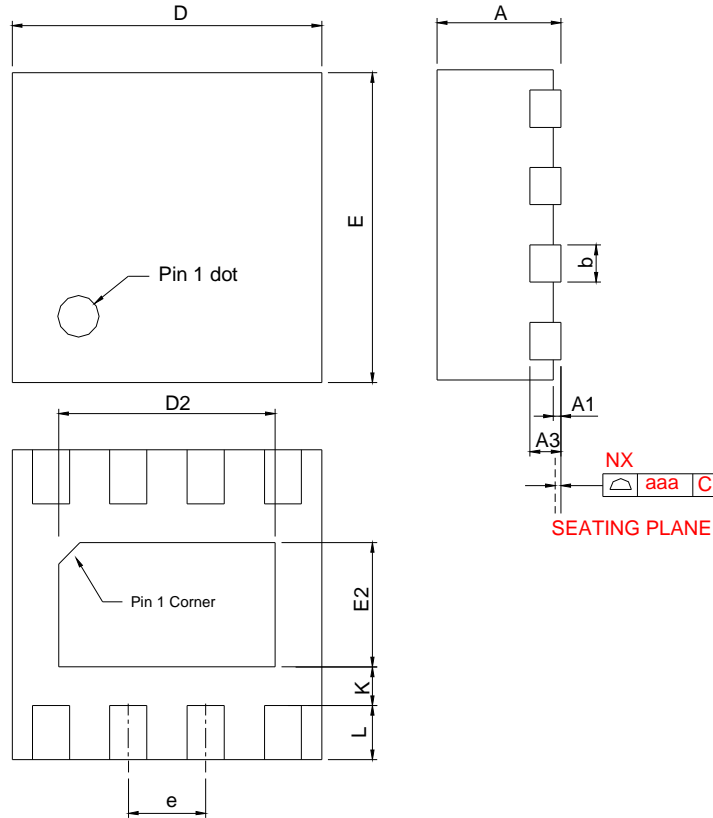

SYMBOL	TDFN2*2-8			
	MILLIMETERS		INCHES	
	MIN.	MAX.	MIN.	MAX.
A	0.70	0.80	0.028	0.031
A1	0.00	0.05	0.000	0.002
A3	0.20 REF		0.008 REF	
b	0.18	0.30	0.007	0.012
D	1.90	2.10	0.075	0.083
D2	1.00	1.60	0.039	0.063
E	1.90	2.10	0.075	0.083
E2	0.60	1.00	0.024	0.039
e	0.50 BSC		0.020 BSC	
L	0.30	0.45	0.012	0.018
K	0.20		0.008	
aaa	0.08		0.003	

Note : 1. Follow from JEDEC MO-229 WCCD-3.

Carrier Tape & Reel Dimensions

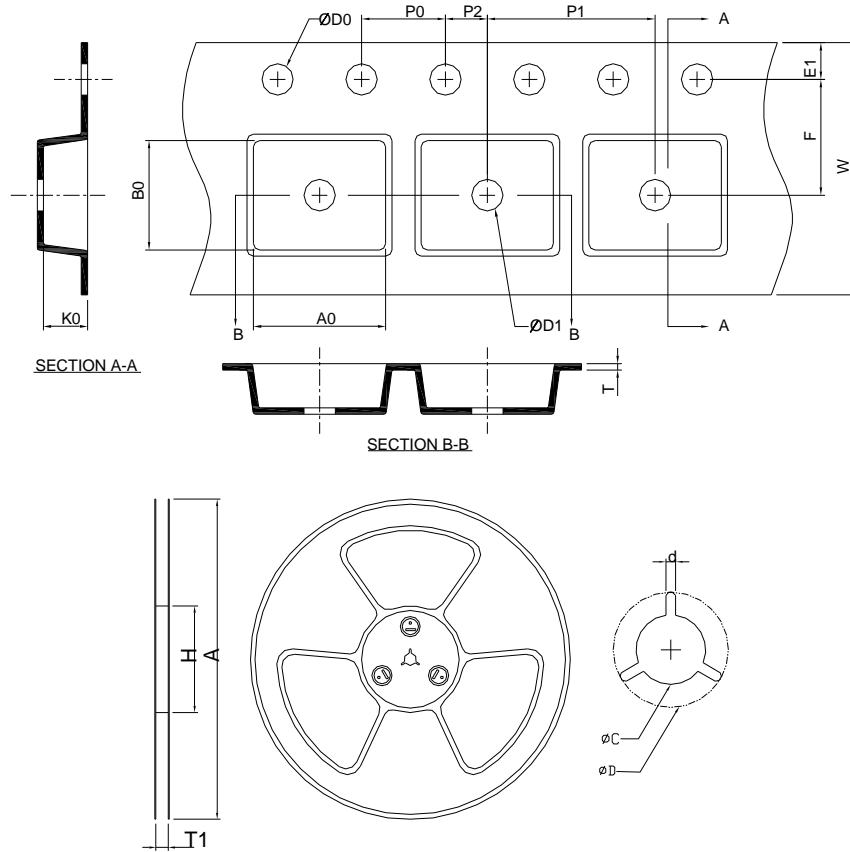

Application	A	H	T1	C	d	D	W	E1	F
SOP-8P	330.0±2.00	50 MIN.	12.4+2.00 -0.00	13.0+0.50 -0.20	1.5 MIN.	20.2 MIN.	12.0±0.30	1.75±0.10	5.5±0.05
	P0	P1	P2	D0	D1	T	A0	B0	K0
	4.0±0.10	8.0±0.10	2.0±0.05	1.5+0.10 -0.00	1.5 MIN.	0.6+0.00 -0.40	6.40±0.20	5.20±0.20	2.10±0.20
Application	A	H	T1	C	d	D	W	E1	F
TDFN3x3-10	330.0±2.00	50 MIN.	12.4+2.00 -0.00	13.0+0.50 -0.20	1.5 MIN.	20.2 MIN.	12.0±0.30	1.75±0.10	5.5±0.05
	P0	P1	P2	D0	D1	T	A0	B0	K0
	4.0±0.10	8.0±0.10	2.0±0.05	1.5+0.10 -0.00	1.5 MIN.	0.6+0.00 -0.40	3.30±0.20	3.30±0.20	1.30±0.20
Application	A	H	T1	C	d	D	W	E1	F
TDFN2x2-8	178.0±2.00	50 MIN.	8.4+2.00 -0.00	13.0+0.50 -0.20	1.5 MIN.	20.2 MIN.	8.0±0.20	1.75±0.10	3.50±0.05
	P0	P1	P2	D0	D1	T	A0	B0	K0
	4.0±0.10	4.0±0.10	2.0±0.05	1.5+0.10 -0.00	1.5 MIN.	0.6+0.00 -0.4	2.35±0.20	2.35±0.20	1.00±0.20

(mm)

Application	A	H	T1	C	d	D	W	E1	F
SOT-23-5	178.0±2.00	50 MIN.	8.4+2.00 -0.00	13.0+0.50 -0.20	1.5 MIN.	20.2 MIN.	8.0±0.30	1.75±0.10	3.5±0.05
	P0	P1	P2	D0	D1	T	A0	B0	K0
	4.0±0.10	4.0±0.10	2.0±0.05	1.5+0.10 -0.00	1.0 MIN.	0.6+0.00 -0.40	3.20±0.20	3.10±0.20	1.50±0.20
Application	A	H	T1	C	d	D	W	E1	F
SOT-23-6	178.0±2.00	50 MIN.	8.4+2.00 -0.00	13.0+0.50 -0.20	1.5 MIN.	20.2 MIN.	8.0±0.30	1.75±0.10	3.5±0.05
	P0	P1	P2	D0	D1	T	A0	B0	K0
	4.0±0.10	4.0±0.10	2.0±0.05	1.5+0.10 -0.00	1.0 MIN.	0.6+0.00 -0.40	3.20±0.20	3.10±0.20	1.50±0.20

(mm)

Devices Per Unit

Package Type	Unit	Quantity
SOP- 8P	Tape & Reel	2500
TDFN-3x3-10	Tape & Reel	3000
TDFN2x2-8	Tape & Reel	3000
SOT-23-5	Tape & Reel	3000
SOT-23-6	Tape & Reel	3000

Taping Direction Information

SOP-8P

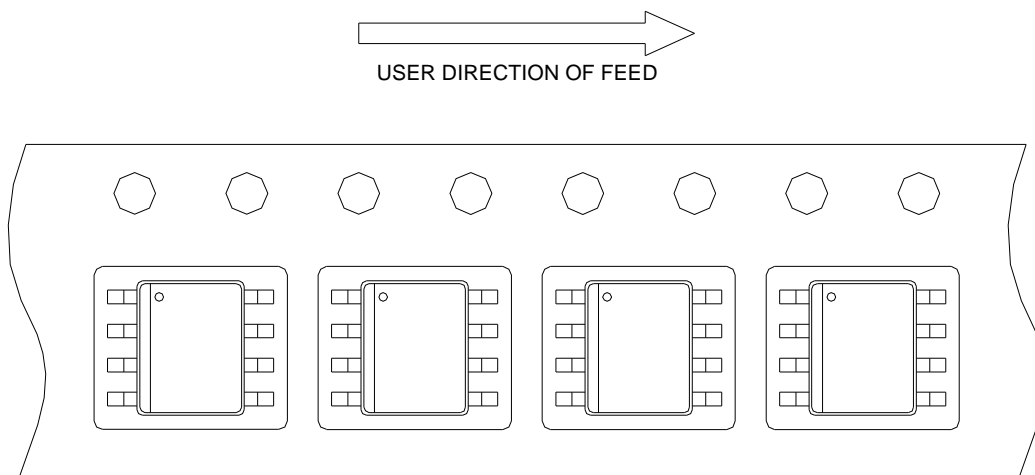

Taping Direction Information

TDFN3x3-10

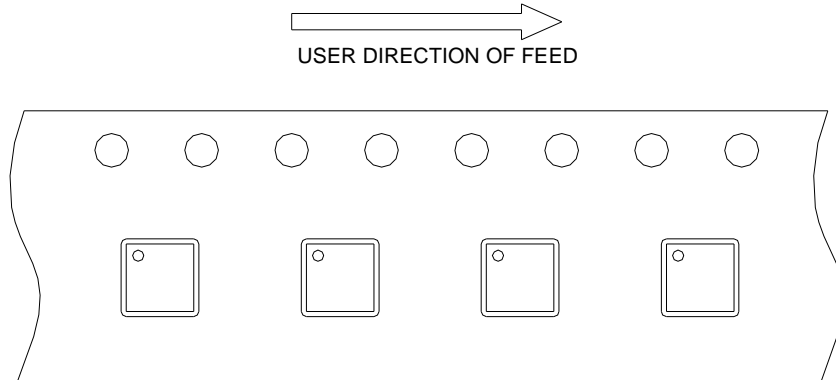

TDFN2x2-8

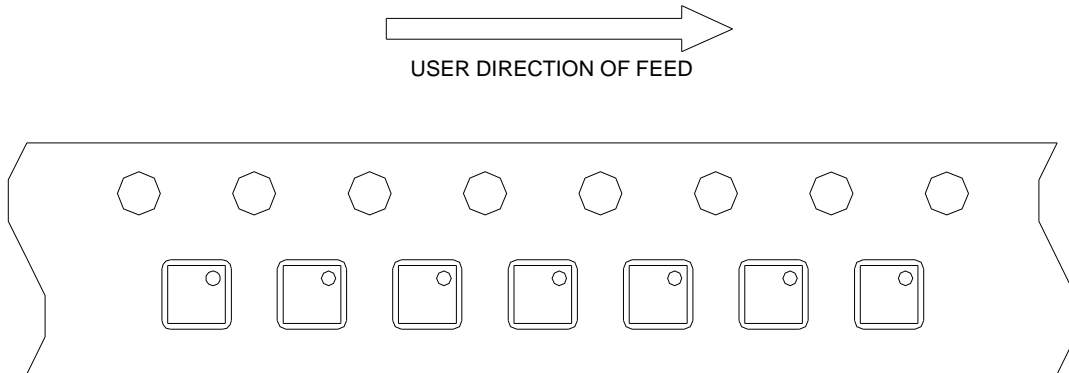

SOT-23-6

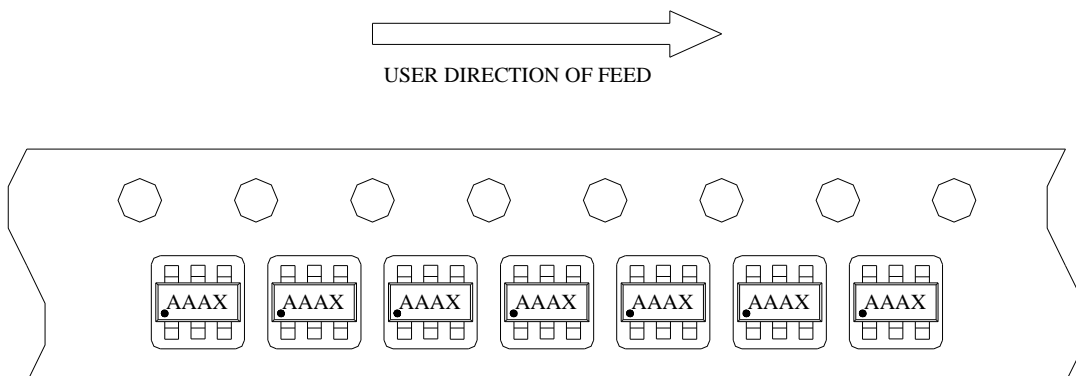

Taping Direction Information

SOT-23-5

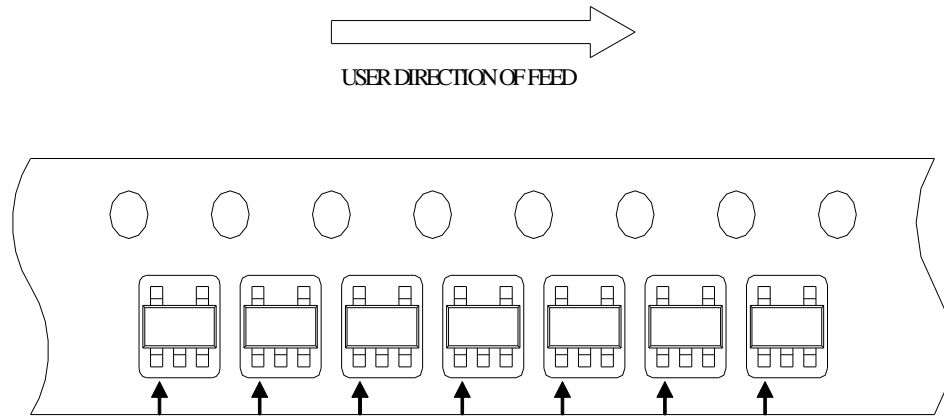

Note: Pin 1 position as indicated by the arrow.

Classification Profile

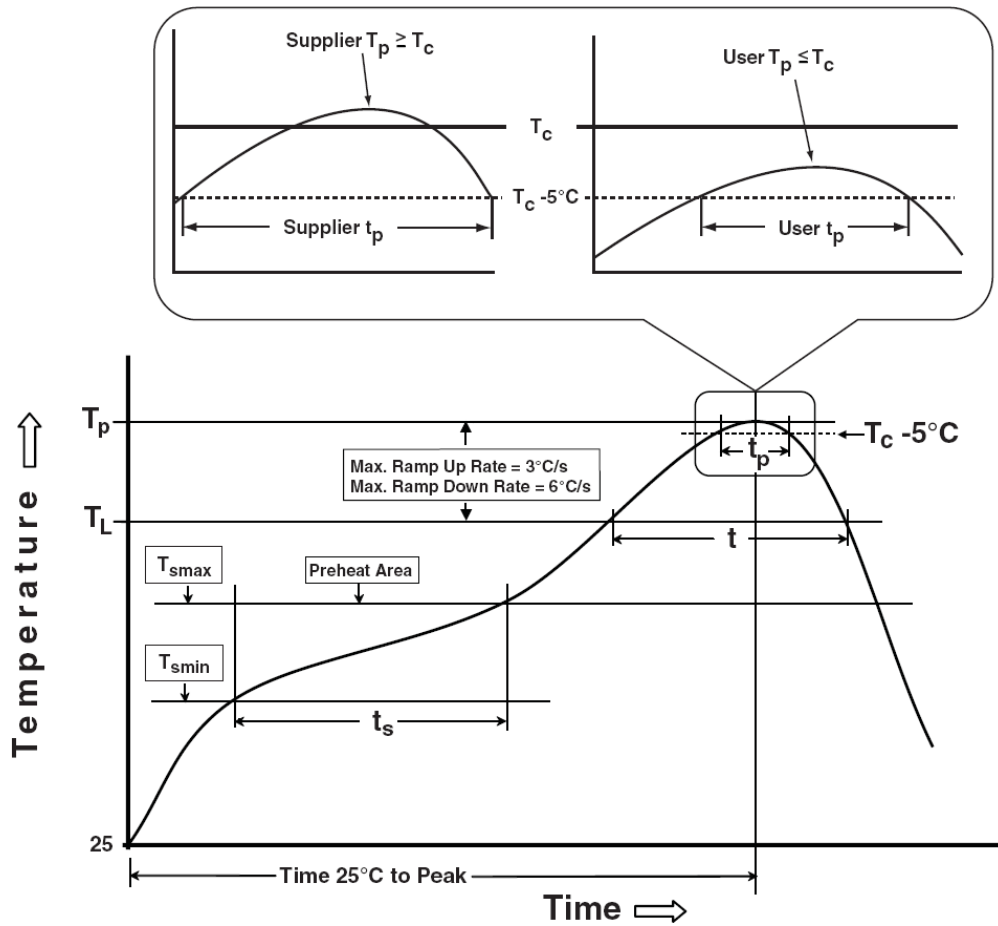

Classification Reflow Profiles

Profile Feature	Sn-Pb Eutectic Assembly	Pb-Free Assembly
Preheat & Soak		
Temperature min (T_{smin})	100 °C	150 °C
Temperature max (T_{smax})	150 °C	200 °C
Time (T_{smin} to T_{smax}) (t_s)	60-120 seconds	60-120 seconds
Average ramp-up rate (T_{smax} to T_p)	3 °C/second max.	3°C/second max.
Liquidous temperature (T_L)	183 °C	217 °C
Time at liquidous (t_L)	60-150 seconds	60-150 seconds
Peak package body Temperature (T_p)*	See Classification Temp in table 1	See Classification Temp in table 2
Time (t_p)** within 5°C of the specified classification temperature (T_c)	20** seconds	30** seconds
Average ramp-down rate (T_p to T_{smax})	6 °C/second max.	6 °C/second max.
Time 25°C to peak temperature	6 minutes max.	8 minutes max.
* Tolerance for peak profile Temperature (T_p) is defined as a supplier minimum and a user maximum.		
** Tolerance for time at peak profile temperature (t_p) is defined as a supplier minimum and a user maximum.		

Table 1. SnPb Eutectic Process – Classification Temperatures (T_c)

Package Thickness	Volume mm ³ <350	Volume mm ³ ≥350
<2.5 mm	235 °C	220 °C
≥2.5 mm	220 °C	220 °C

Table 2. Pb-free Process – Classification Temperatures (T_c)

Package Thickness	Volume mm ³ <350	Volume mm ³ 350-2000	Volume mm ³ >2000
<1.6 mm	260 °C	260 °C	260 °C
1.6 mm – 2.5 mm	260 °C	250 °C	245 °C
≥2.5 mm	250 °C	245 °C	245 °C

Reliability Test Program

Test item	Method	Description
SOLDERABILITY	JESD-22, B102	5 Sec, 245°C
HOLT	JESD-22, A108	1000 Hrs, Bias @ $T_j=125^\circ\text{C}$
PCT	JESD-22, A102	168 Hrs, 100%RH, 2atm, 121°C
TCT	JESD-22, A104	500 Cycles, -65°C~150°C
HBM	MIL-STD-883-3015.7	VHBM ≥ 2KV
MM	JESD-22, A115	VMM ≥ 200V
Latch-Up	JESD 78	10ms, $1_{tr} \geq 100\text{mA}$

Customer Service

Anpec Electronics Corp.

Head Office :

No.6, Dusing 1st Road, SBIP,

Hsin-Chu, Taiwan, R.O.C.

Tel : 886-3-5642000

Fax : 886-3-5642050

Taipei Branch :

2F, No. 11, Lane 218, Sec 2 Jhongsing Rd.,

Sindian City, Taipei County 23146, Taiwan

Tel : 886-2-2910-3838

Fax : 886-2-2917-3838