

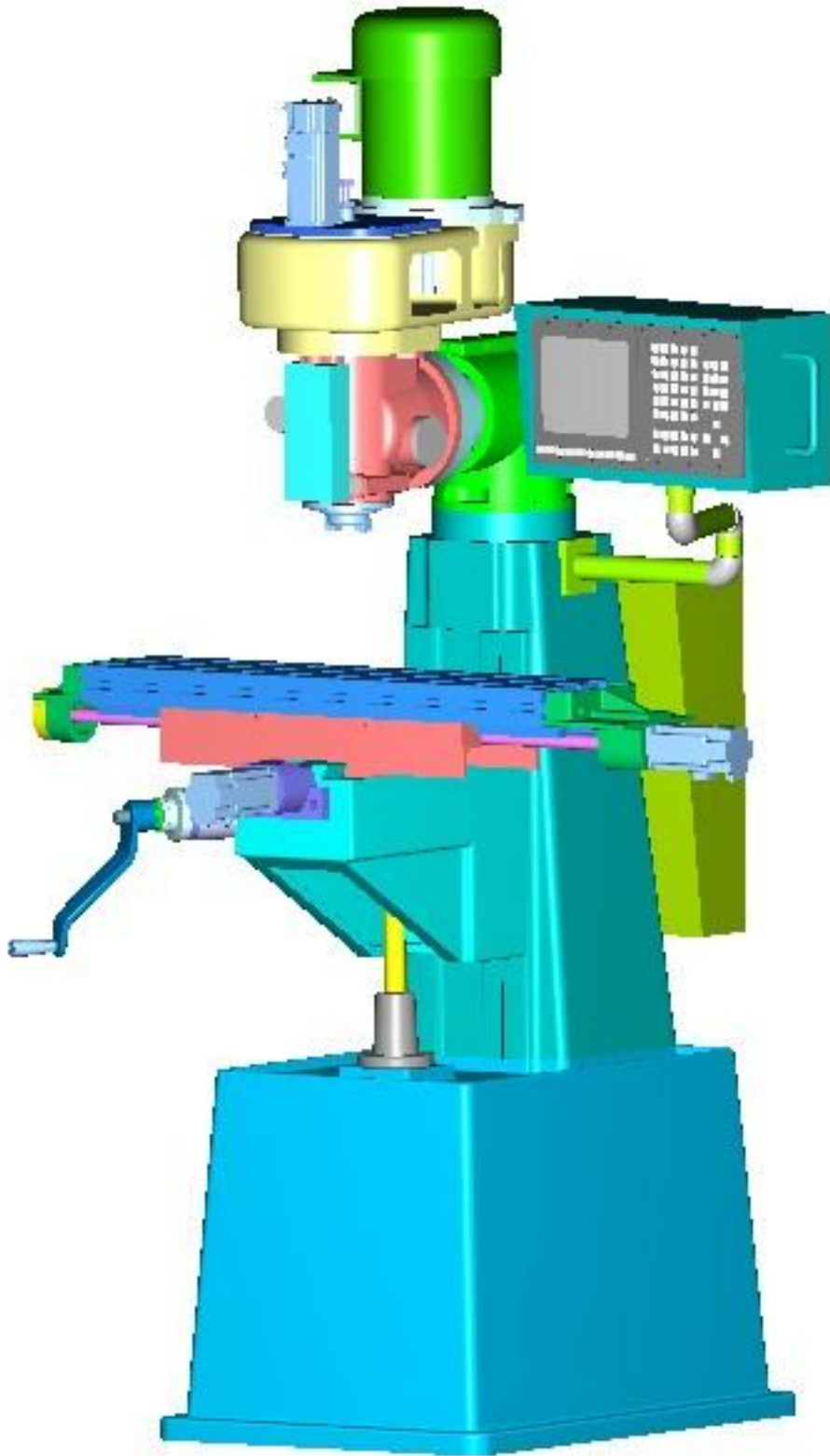

# LIAN JENG CORPORATION

No.168, Guangqi Rd., Shengang Dist., Taichung City 42948, Taiwan  
Tel: 886-4-25625559 Fax: 886-4-25626827 <http://www.lianjeng.com> E-mail: [sales@lianjeng.com](mailto:sales@lianjeng.com)

---



**NC milling machine 數控銑床 CF-A2NC**

Models (CF-A2NC)	
Table 工作台	
Working surface(length*Width)面積	760x180mm
Traveling (X / Y / Z)行程	480x200x350mm
T-Slots T 型槽	16mmx3
Vertical Spindle 立主軸	
Spindle nose 主軸錐度	N.T.#30
Spindle speeds (R.P.M.) 轉速	3,500 r.p.m
Distance from spindle end to table top 主軸端度工作台面距離	50-350mm
Vertical travel of quill 通心軸行程	80mm
Swiveling angle of head(right & left)左右傾斜角	90°
Cross travel of ram 伸出臂行程	180mm
Horizontal rotation angle or ram 水平旋轉角度	360°
Motor 馬達	
For vertical spindle 主軸馬達	1.5KW
For X/Y feed X/Y 軸進給馬達	0.4KW
For Vertical of quill feed 通心軸進給馬達	0.4Kw
For cutting fluid pump 冷卻裝置馬達	0.1KW-4P
Size 尺寸	
Net weight(approx.) 淨重	600kg
Dimensions of machine(approx.) 佔地面積	1200x1100x2000mm

All specification and designs are subject to change without notice.