Solar LED Light Series Product



Solar Ground Lighting is grid-independent stand alone plug-and-play system designed to provide contemporary aesthetic illumination for outdoor residential, commercial and industrial spaces.

EWatts Solar LED Ground Lights are manufactured in accordance with ISO 9001 Standards and have received CE, SGS and SGS IP68 Certifications.

- 1. 100% solar powered device, free of electrical wires**
- 2. Easy installation – no wiring**
- 3. Anti-theft design – unique locking tools**
- 4. Non-glass Bayer anti-UV PC shell - withstands 12 tons 15 tons 24 tons 27 tons**
- 5. Highest waterproof rating IP68**
- 6. Lithium iron phosphate battery offers endurance and longer life span.**
- 7. SU 316 stainless steel cover with non-slip surface in an attractive embedded design**



Features

maintenance-free solar electricity to save energy to reduce Co2 emissions

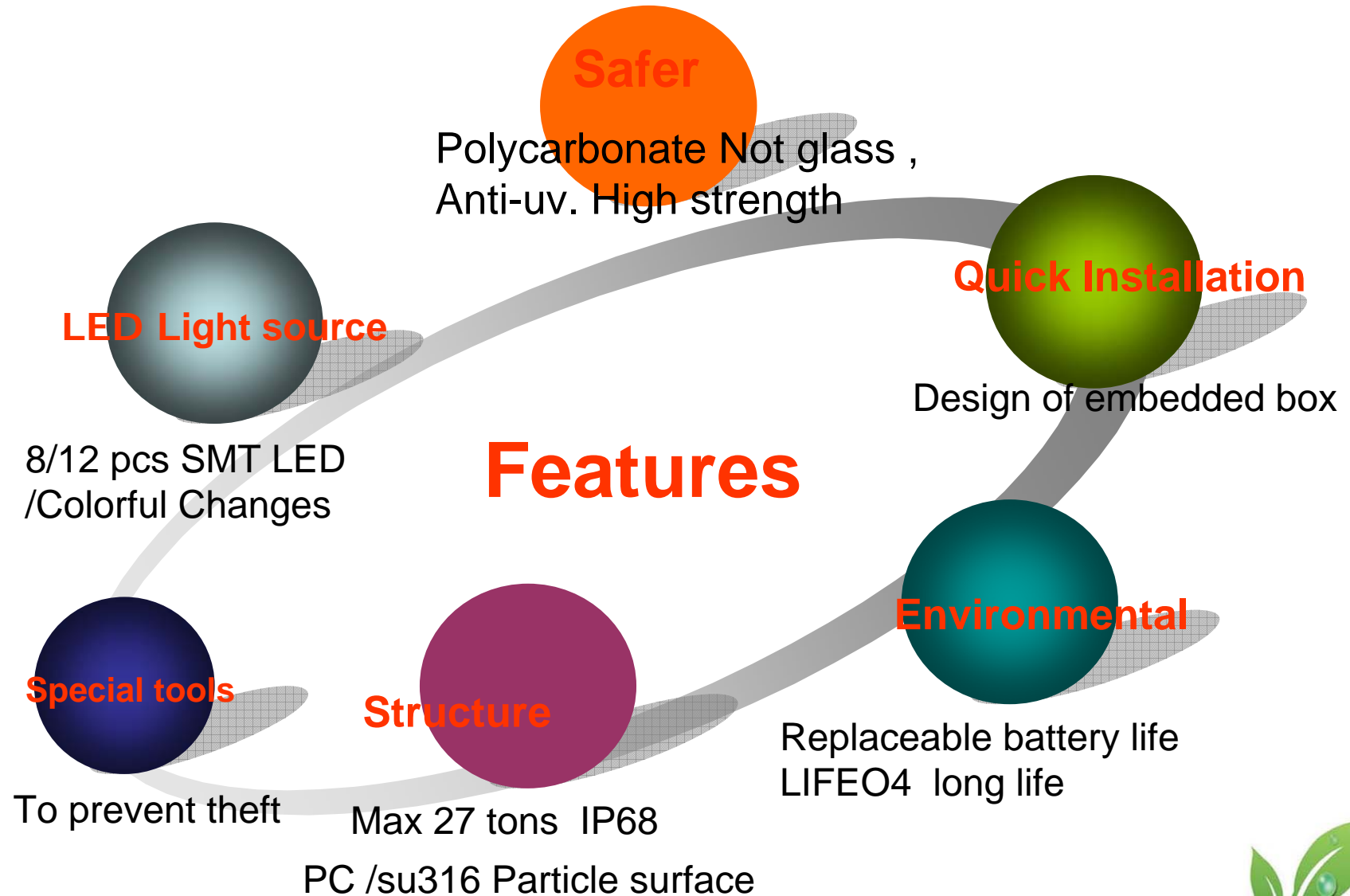

Application



Road guide, pool



Park Area



Ads solar tiles



Park Trail

Product use

Building exteriors, Boardwalks, Fountains, Facades
Helipads – Flash Mode, Landscapes, Pavers
Pool decks, Patios, Pathways, Stairways, Security –
Flash Mode, Sundecks.....

Safer and more beautiful



Buliding



Certificate

- **Made In Taiwan**
DNV / ISO9001-2008, ISO14001:2004
UL, 3C



DET NORSKE VERITAS
MANAGEMENT SYSTEM CERTIFICATE

Certificate No. 91235-2011-AE-RGC-RvA

This is to certify that

Yenom Technology Services Inc.

3F1 & 4F1, No. 37, Wu-Chuan Rd., Wu Ku Industrial Park, Wuku Shiang, Taipei, 248, Taiwan

has been found to conform to the Management System Standard:

ISO 14001:2004

This Certificate is valid for the following product or service ranges:

**Manufacture of Computer, Communication and Consumer
Peripherals Cards, Hubs and Power Supply**

Initial Certification date: January 26th, 2011

Place and date: Taipei, January 26th, 2011

This Certificate is valid until: January 26th, 2014

The audit has been performed under the supervision of
Fred Cheng
Lead Auditor



for the Accredited Unit:
DNV CERTIFICATION B.V.,
THE NETHERLANDS

Chen Yi
Management Representative

Lack of fulfillment of conditions as set out in the Certification Agreement may render this Certificate invalid.
Det Norske Veritas Certification B.V. Zwolweg 1, 2004 LB Breda, The Netherlands, TEL: +31 10 322 681 - www.dnv.com / www.dnv.nl



DET NORSKE VERITAS
MANAGEMENT SYSTEM CERTIFICATE

Master Certificate No. 0445-2001-AQ-RGC-RvA

This is to certify that

**Yenom Technology Services Inc.
Pronology Services Inc.**

3F1 & 4F1, No. 37, Wu-Chuan Rd., Wu Ku Industrial Park, Wuku Shiang, Taipei, Taiwan;
2nd Industrial Zone, Lou Village, Gongming, Baoan, Shenzhen City, Guangdong, China

has been found to conform to the Management System Standard:

ISO 9001:2008

This Certificate is valid for the following product or service ranges:

**Manufacture of Computer, Communication and Consumer
Peripherals Cards, Hubs and Power Supply**

Initial Certification date: January 12th, 2001

Place and date: Taipei, January 20th, 2010

This Certificate is valid until: January 12th, 2013

The audit has been performed under the supervision of
Tony Lin
Lead Auditor



for the Accredited Unit:
DNV CERTIFICATION B.V.,
THE NETHERLANDS

Chen Yi
Management Representative

Lack of fulfillment of conditions as set out in the Certification Agreement may render this Certificate invalid.
Det Norske Veritas Certification B.V. Zwolweg 1, 2004 LB Breda, The Netherlands, TEL: +31 10 322 681 - www.dnv.com / www.dnv.nl



Equipment



IC Programming



PCB Baker



N2 Generator



SMT Line



Solder Paste Inspector



Dehumidifier



Stencil Cleaner

3 x SMT Lines

- * 3 x Loader/ Unloader (Large size)
- * 3 x Ekra 2D inspection screen printer (Large size-550*550mm)
- * 1 x Sanyo Dispenser Machine (Large size-360x460mm)
- * 2 x Sanyo Hi-speed Mounter(Large size-360x460mm)
- * 2 x Sanyo multi-functional mounter (Large size-381x460mm)
- * 1 x Panasonic Hi-speed Machine (Middle size-330x250mm)
- * 1 x Panasonic multi-functional mounter (Middle size-330x250mm)
- * Vitronics & 2 x Folungwin N2 Reflow (PCB width-63.5~457mm)
- * Kurasep N2 Generator
- * 2 x Air Compressor
- * Solder Paste stirrer
- * SMD component Tapping machine
- * 2 x PCB Baker
- * 2 x HiLo IC Programmer
- * 3 x Marantz AOI machine
- * 1 x Solder Paste Inspector
- * 1 x Stencil Cleaner



Visual Inspection



AOI Machine



Equipment



Forming Area



Manual Insertion Line

2 * DIP insertion Line

- * X* *Forming Equipment*
- * 2 * *DIP insertion conveyor*
- * 2 * *Lead Free Soldering Machine with Spray Flux Machine*
- * 2 * *Slicer PCB cutting Machine*
- * 3 * *Touch-Up line*
- * X* *Temperature control soldering Iron*
- * X* *40X Magnifier*
- * 1 * *TRI ICT Machine*



I.P.Q.C.



ICT Machine



Soldering Machine



Touch Up Line



PCBA Cleaner



PCBA Slicer



Press fit





Testing Line

Engineering

- * *Meisho BGA rework machine*
- * *Hakko SMT rework machine*
- * *Hitachi Oscilloscope*
- * *Temperature control soldering Iron*

Assembly Line

- * *Assembly Conveyor* 2 lines*
- * *Testing Stations* 70 sets*
- * *50 °C Burn-in room*
- * *60 °C Burn-in Chamber*
- * *48V DC power Burn-in source*
- * *Bar Code Scanner & Printer* 4 sets*
- * *Torque Meter* 1pc*



Palletized



Assembly Line

Packing Line

- * *Packing Conveyor* 2 lines*
- * *Bar Code Scanner & Printer* 3 sets*
- * *Clamshell Ultrasonic press machine*
- * *High Frequency plastic press machine*
- * *Shrink packing machine*
- * *Scales*



Plastic Case Assy



Burn-in Room



60°C Chamber



Packing line



Shrink Packing



Clamshell Pack



Quality Assurance

- * Multi meter for IQC
- * Hi-Pot Tester
- * Force gauge meter
- * Micro Scope
- * Rohs X-ray Tester
- * Vacuum Packing machine for Humility sensitive parts
- * High Temperature Chamber for Reliability (Over 60 °C)
- * 24 hrs SMT/DIP material Temp/Humidity control system



Vacuum Packing Machine



I.Q.C



FQA



High Temp Chamber



ESD Impedance Tester



Hi_Pot Tester



Force Gauge Meter



Micro Scope



RoHS X-ray Machine



LCR Meter

Products

SR203 (for small)

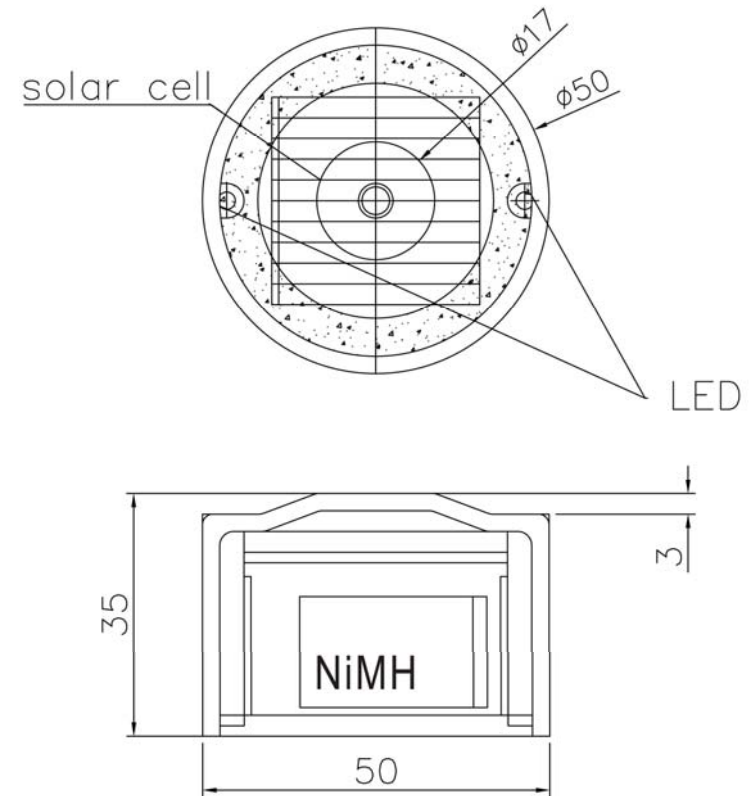

Solar LED Ground Light –

1. Bayer PC, Option Su316 Stainless Steel Flange
2. SMT LED 1 or 2 PCS (Color: RGBYW)
3. LED Mode: Steady Flash (2 Hz)
4. NiMH Battery 1.2V 800maH **Rechargeable and can be updated**
5. Size L Dim 50mm x H 35mm 200g
6. Coefficient test: SGS, IP68 ,CE, 6. Withstand 5 tons **Salt spray test**



SR106 (cat eye for Road)

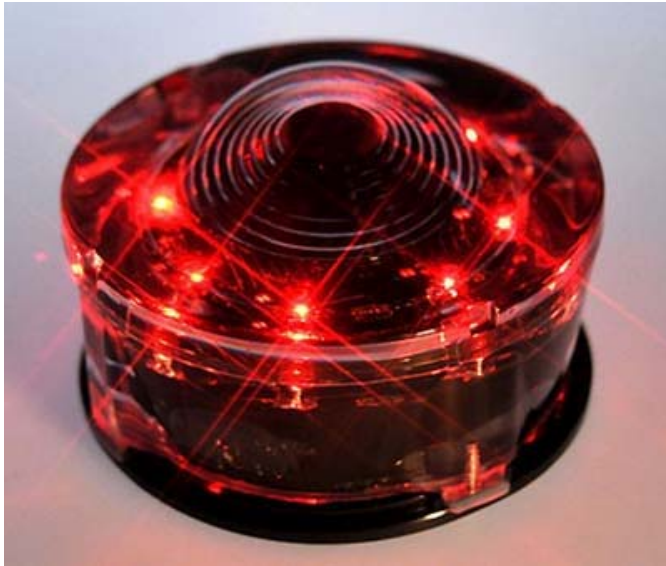

Solar LED Ground Light –

1. Bayer PC
2. SMT LED 8 /12 PCS (Color: RBYW)
3. LED Mode: Steady Flash (2 Hz/1HZ)
4. Lifo4 Battery 3.2V 1800maH

Rechargeable and can be updated

5. Size L Dim 100mm x H70mm 500g

6. Coefficient test: SGS, IP68 ,CE, 6. Withstand 24 tons **Salt spray test**

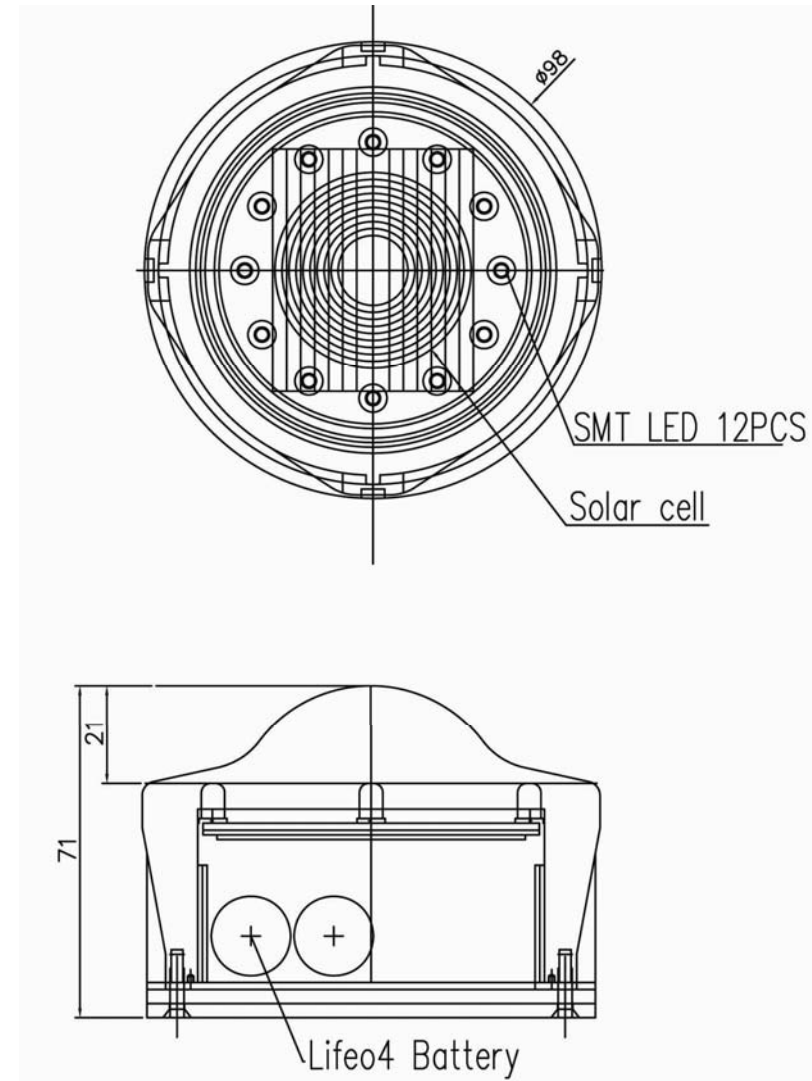

SR204 (For Park and Wall)



Solar LED Ground Light –

1. Bayer PC
2. SMT LED 8 /12 PCS (Color: RGBYW and full color)
3. LED Mode: Steady Flash (2 Hz) and Gradually light
4. Lifeo4 Battery 3.2V 1800maH

Rechargeable and can be updated

5. Size L Dim 90mm x H 50mm 500g

6. Coefficient test: SGS, IP68 ,CE, 6. Withstand 10 tons **Salt spray test**

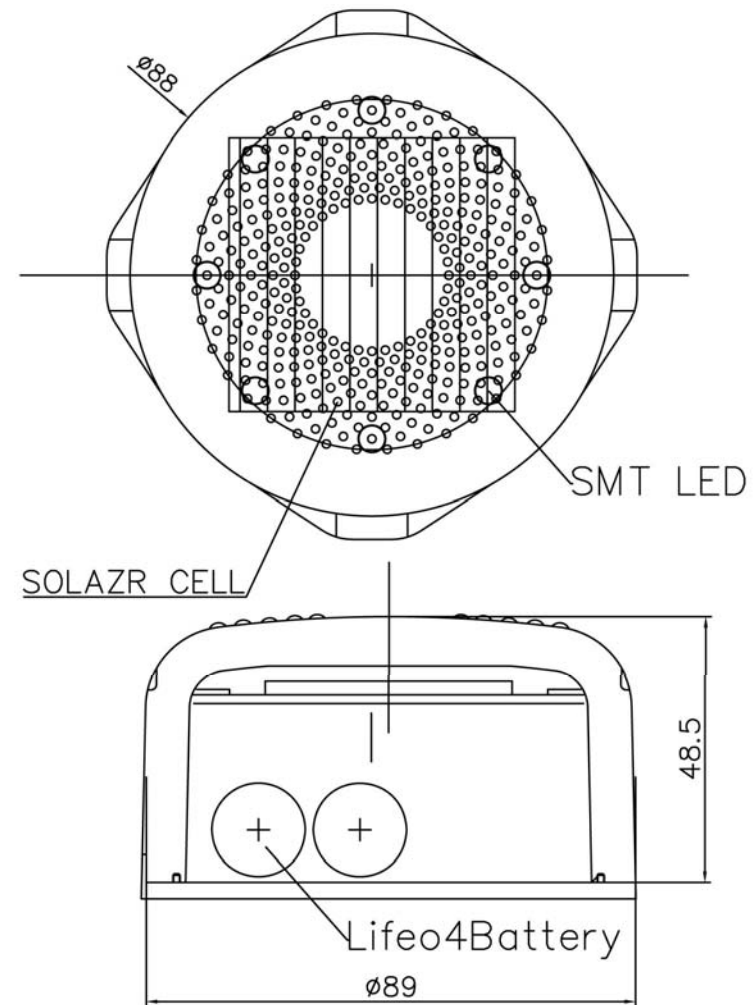

Products

SR205

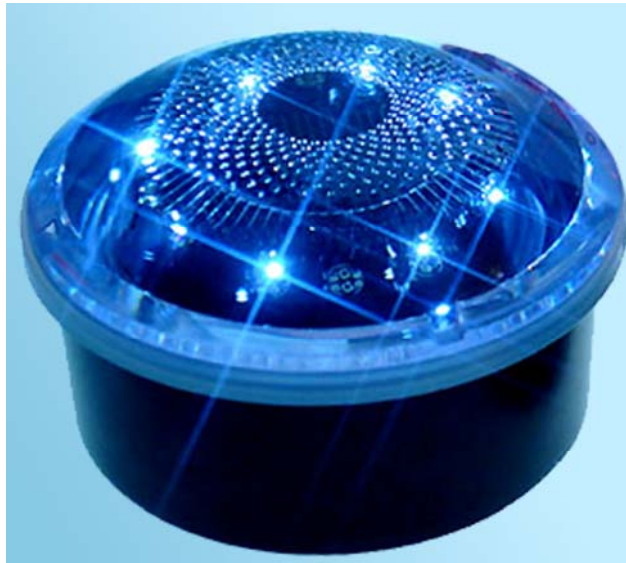

Solar LED Ground Light –

1. Bayer PC, AL case (embedded box)
2. SMT LED 8 / 12 PCS (Color: RGBYW and full color)
3. LED Mode: Steady Flash (2 Hz) and Gradually light Gradually dark
4. Lifeo4 Battery 3.2V 1800mAh
Rechargeable and can be updated
5. Size L Dim 120mm x H 70mm 750g
6. Coefficient test: SGS, IP68, CE, 6. Withstand 20 tons
Salt spray test

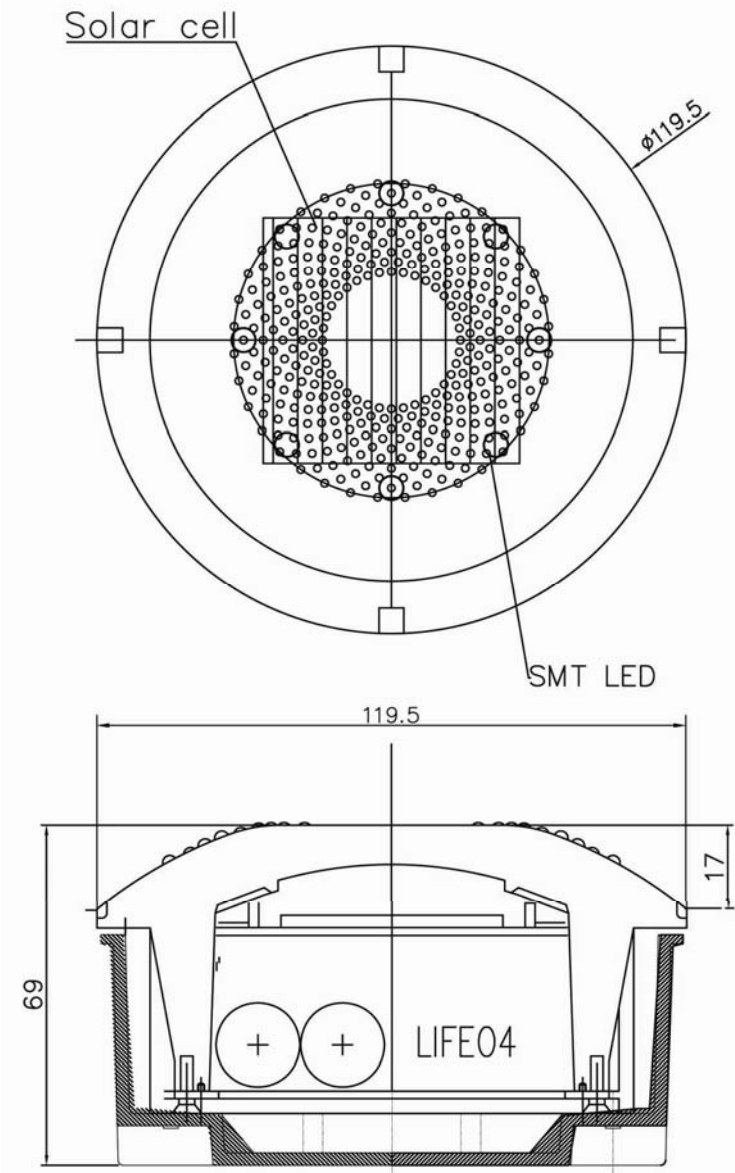

Products

SR100

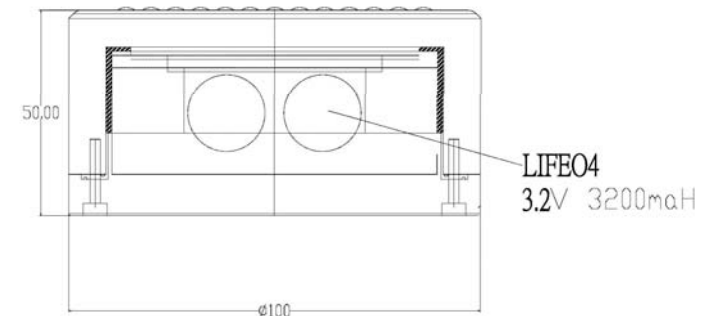
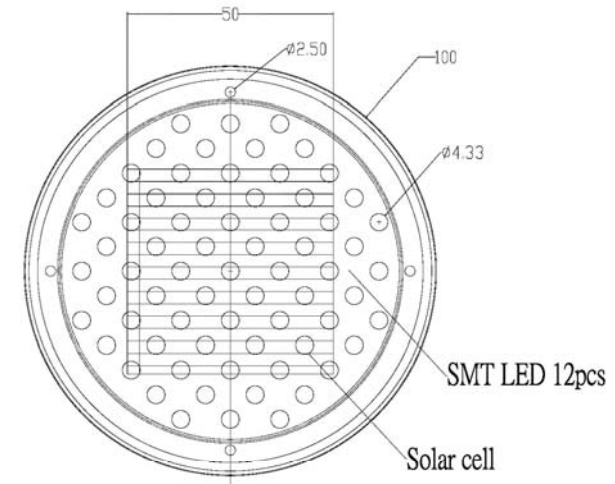

Solar LED Ground Light –

1. Bayer PC, Su316 Stainless Steel Flange AL case
2. SMT LED 8 /12 PCS (Color: RGBYW and full color)
3. LED Mode: Steady Flash (2 Hz) and Gradually light Gradually dark
4. Lifo4 Battery 3.2V 1800maH **Rechargeable and can be updated**
5. Size LDim 100mm x H50mm 650g
6. Coefficient test: SGS, IP68 ,CE, 6. Withstand 16 tons **Salt spray test**



Win701



Solar LED Ground Light –

1. Bayer PC, Su316 Stainless Steel Flange AL case
2. SMT LED 8 /12 PCS (Color: RGBYW and full color)
3. LED Mode: Steady Flash (2 Hz) and Gradually light Gradually dark
4. Lifeo4 Battery 3.2V 1800maH **Rechargeable and can be updated**
5. Size L Dim 125mm x H65mm 1100g
6. Coefficient test: SGS, IP68 ,CE, 6. Withstand 27 tons **Salt spray test**

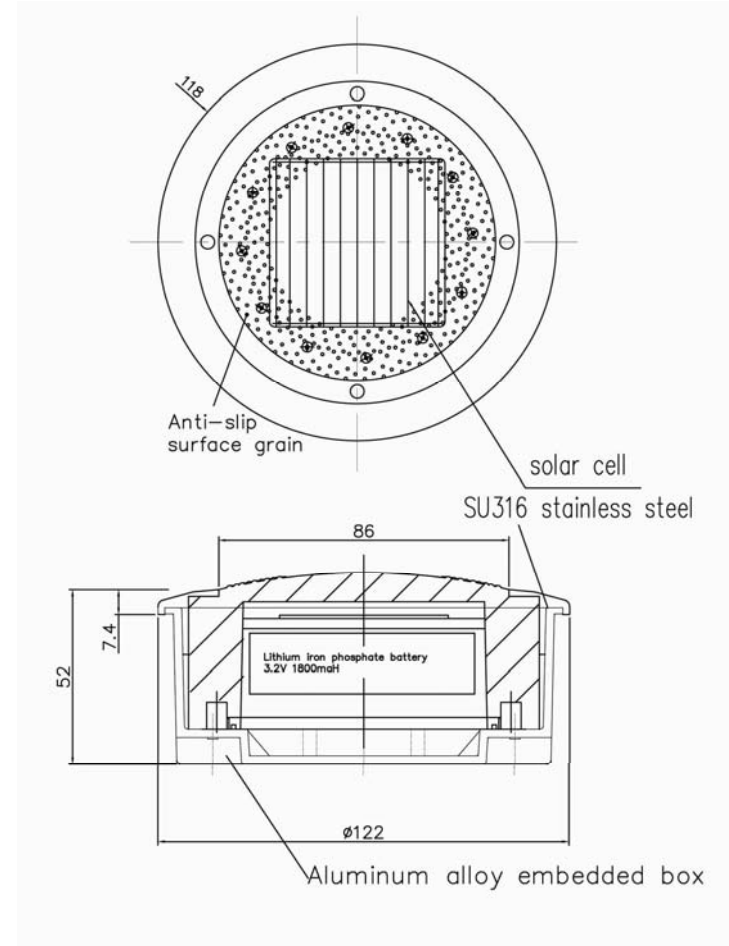

Star523 (for Road Mark)

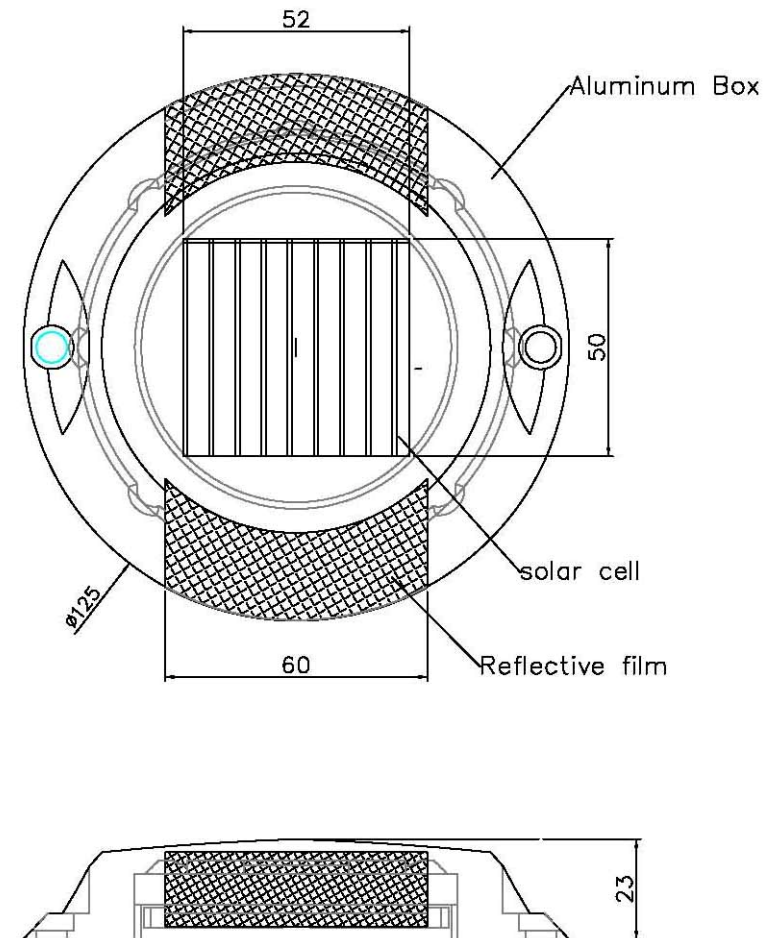

Solar LED Ground Light –

1. AL case
2. SMT LED 8 /12 PCS (Color: RGBYW)
3. LED Mode: Steady Flash (2 Hz) and Gradually light Gradually dark
4. Lifeo4 Battery 3.2V 700maH
5. Size LDim 125mm x H23mm 450g
6. Coefficient test: SGS, IP68 ,CE, 6. Withstand 24 tons **Salt spray test**



Products

SB100 (it can put logo)

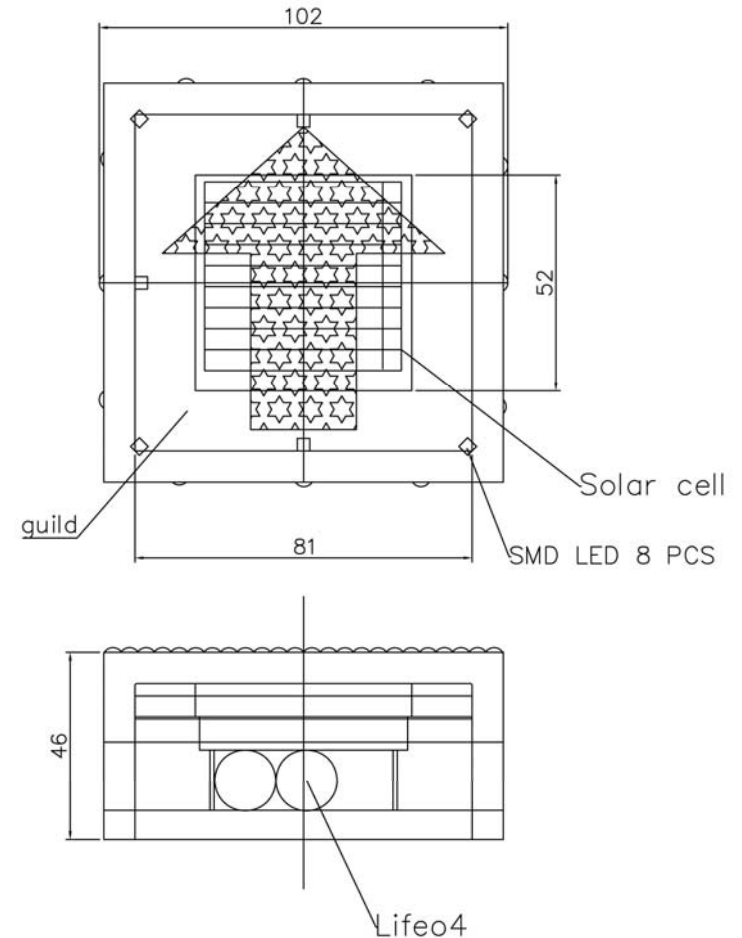
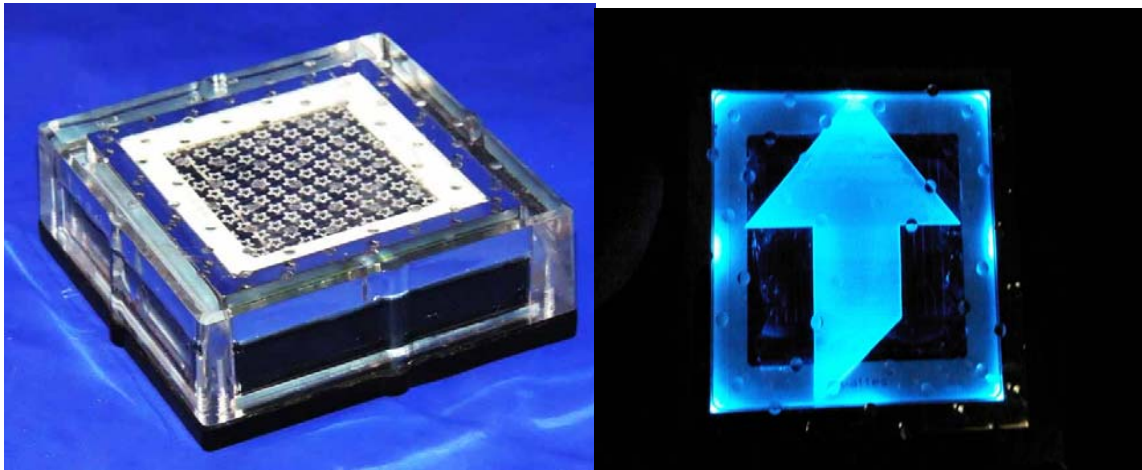

Solar LED Ground Light –

1. Bayer PC,
2. SMT LED 8 PCS (Color: RGBYW and full color)
3. LED Mode: Steady Flash (2 Hz) and Gradually light Grad
4. Lifeo4 Battery 3.2V 1800maH **Rechargeable and can be updated**
5. Size L100mm x100mm x40mm 400g
6. Coefficient test: SGS, IP68 ,CE, 6. Withstand 10 tons **Salt spray test**



Products

SB200 (it can put logo)



Solar LED Ground Light –

1. Bayer PC,
2. SMT LED 8 PCS (Color: RGBYW and full color)
3. LED Mode: Steady Flash (2 Hz) and Gradually light Gradually dark
4. Lipo4 Battery 3.2V 3600maH **Rechargeable and can be updated**
5. Size L 200mm x 200 x H50mm 1500g
6. Coefficient test: SGS, IP68 ,CE, 6. Withstand 20 tons **Salt spray test**

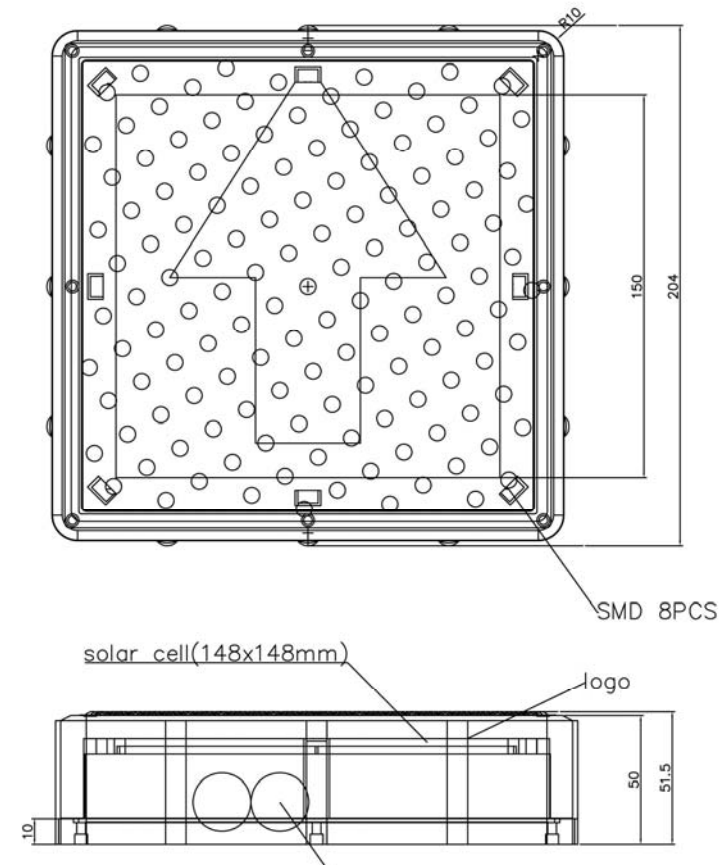

Comparison Chart

	Solar LED Ground Light	LED Ground Light (5w)
Cost		
Surface Temperature	None	Extremely HOT
Transformer	None	Transformers
Installation	easy	Core cut + Cabling
Waterproof Rating	IP68:Dust proof, protected from continuous immersion in water under more severe conditions than 1 meter deep	IP65 Dust proof, protected from splashes and low-pressure jets
Wiring Cost	No	Yes
Maintenance	No (5 years Replace the Battery)	Yes
Electricity Cost	No	Yes
power fee per year	Euro 0.00	ex:100pcs 100x5Wx10hrx365 days xPer kWh electricity /1000=Euro
Co2	No	1162 kgCo2e



Application



Taipei Arena (win701-12B 280pcs)
2008-11 install ~ Taipei

District Square (SR205-8B 140pcs)
2007-10 install~Tamsui

Community Trail (SR205-8B 120pcs)
2005-10 install-Taichung



Application

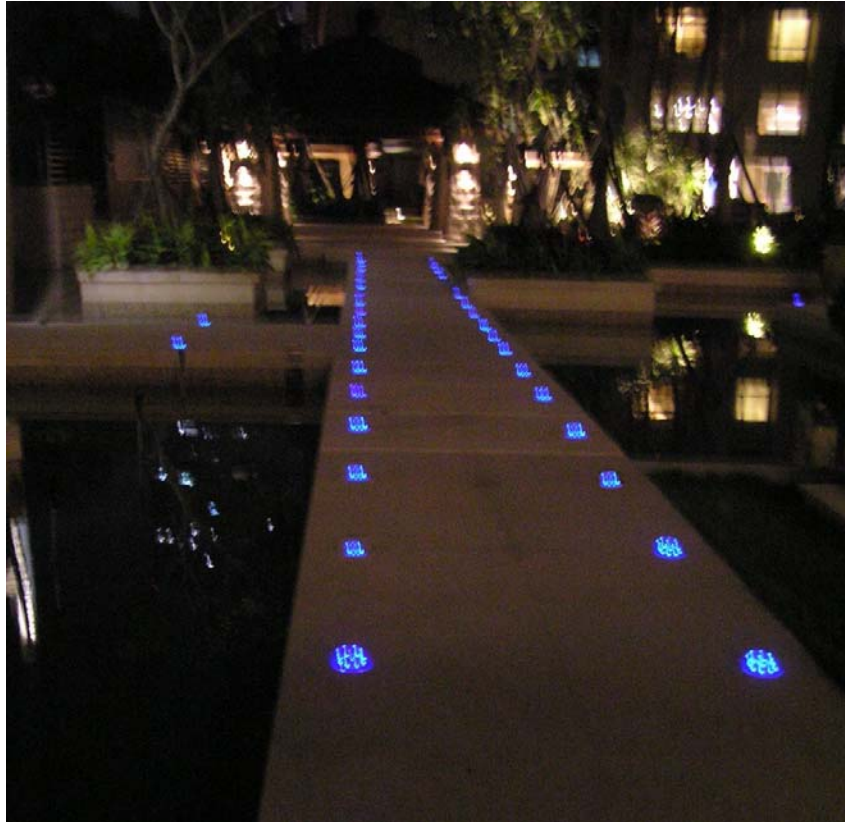

**Building's exterior walls
(SR204-8B flash 350pcs)
2004-5 install-Taichung**

**Pedestrian trails
(SR204-8B 65 PCS 2005-5 Install)**



Application



Trails

SR205-8B 150 PCS

2005-11 Install -Taichung City

Dike

SR106-8B Flash 280pcs

2006-4 install -Keelung City



Application



Parking lot
SR106-8B FLASH 140PCS
2006-4-INSTALL Kaohsiung City



Application



Square

WIN701-8Y 186 PCS

2008-7-Install Taipei city



Application

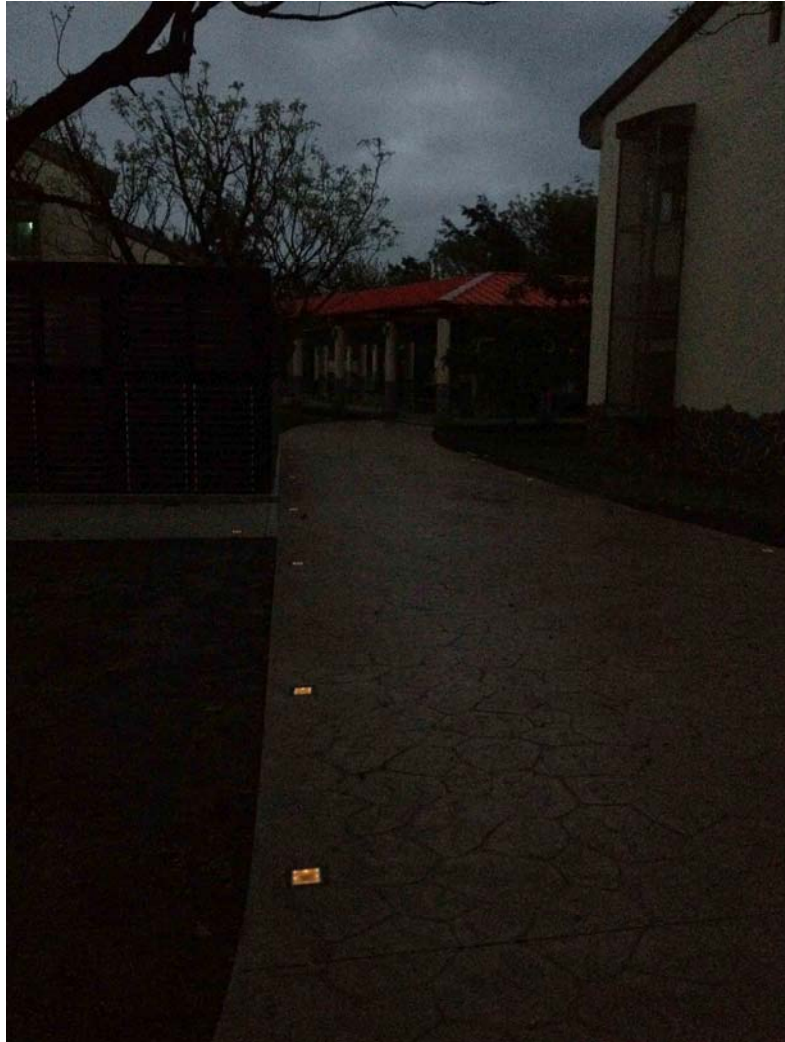

Campsites Area
SB100-8Y 498PCS
2011-11 Install -Yilan County

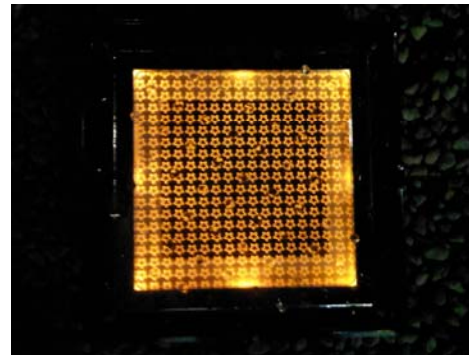

Application



Ramp boundary

Fog zone on the mountain

Star523-6R Flash 460 pcs

New Taipei City



Application



Stonewall
Sr205-8Y-8R-8B-8W
150PCS

2005-7 Install -Taoyuan County



Application



Swimming pool
SR106-8R Flash 40pcs
2008-05 install-indonesia



Application

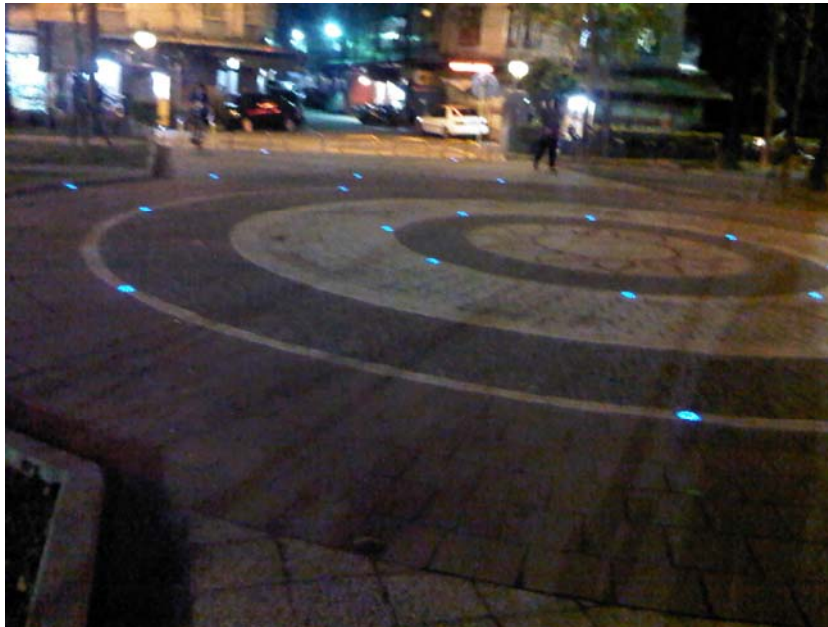

Park
SR205-8B 360PCS
2009-11 Install –new Taipei city



Installation



1



2



3



4



5



6



Thank you

**And God said, “Let there be light,” and there was light.
God saw that the light was good, and He separated the light from the darkness.
~ Genesis 1:3-4**

