

BAR-200

5/32" Heavy Duty Air-Hydraulic Riveter

* Rivet Capacity: 2.4 - 3.2 - 4.0mm (3/32" ~ 5/32")

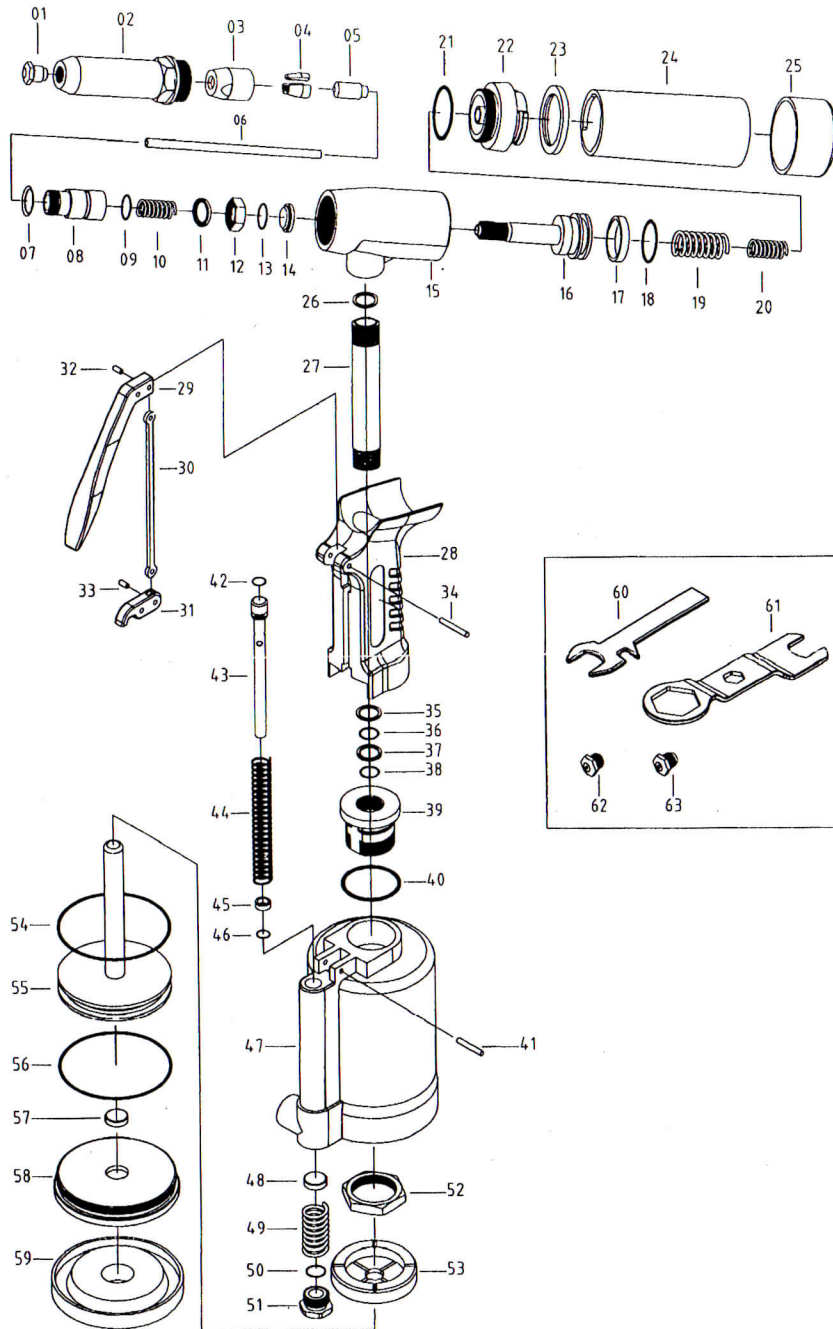

Idex	Description	Q'ty	Idex	Description	Q'ty
1	Nose Piece - 4.0mm	1	33	Spring Pin - Lever	1
2	Frame Head	1	34	Spring Pin - Trigger	1
3	Front Jaw Case	1	35	Seal Ring	1
4	Jaw (3Pcs/Per Set)	1	36	O-Ring	1
5	Jaw Pusher	1	37	Teflon Seal Ring	1
6	Piston Rod	1	38	O-Ring	1
7	Case Washer Ring	1	39	Pipe Frame Base	1
8	Rear Jaw Case	1	40	O-Ring	1
9	O-Ring	1	41	Spring Pin - Cylinder	1
10	Spring - Jaw Pusher	1	42	O-Ring	1
11	Star Washer	1	43	Valve Pusher	1
12	Lock Nut	1	44	Valve Pusher Spring	1
13	O-Ring	1	45	Seal Ring	1
14	Teflon Ring	1	46	O-Ring	1
15	Frame	1	47	Cylinder	1
16	Frame Piston Assy.	1	48	Valve	1
17	Teflon Ring	1	49	Valve Spring	1
18	O-Ring	1	50	O-Ring	1
19	Spring - External	1	51	Valve Cap	1
20	Spring - Internal	1	52	Frame Lock Nut	1
21	O-Ring	1	53	Rubber Cushion	1
22	Frame Cap	1	54	O-Ring	1
23	Rubber Ring	1	55	Cylinder Piston Assy.	1
24	Safety Cap	1	56	O-Ring	1
25	Safety Cap Cover	1	57	Cylinder Cap Cushion	1
26	Seal Ring	1	58	Cylinder Cap	1
27	Pipe Frame	1	59	Protection Base Cover	1
28	Handle	1	60	Gauge Spanner	1
29	Trigger	1	61	Muti-Func. Spanner	1
30	Trigger Rod	1	62	Nose Piece - 2.4mm	1
31	Trigger Lever	1	63	Nose Piece - 3.2mm	1
32	Spring Pin - Rod	1			